

Axial piston variable double pump A24VG series 10



- ▶ Size 85–85, 110–85, 110–110, 125–85, 125–110, 125–125
- ▶ Nominal pressure 450 bar
- ▶ Maximum pressure 500 bar
- ▶ Closed circuit

Features

- ▶ Variable double pump with two axial piston rotary groups with swashplate design for hydrostatic drives in closed circuit
- ▶ The flow is proportional to the drive speed and displacement
- ▶ Two mutually independent flows
- ▶ The flow can be infinitely varied by adjusting the swashplate angle
- ▶ Flow direction changes smoothly when the swashplate is moved through the neutral position
- ▶ Four pressure relief valves are provided on the high-pressure side to protect the hydrostatic gear (pump and motor) from overloading.
- ▶ The high-pressure relief valves also function as boost valves
- ▶ The maximum boost pressure is limited by a built-in low-pressure relief valve
- ▶ High pressure level for high power density and good efficiency
- ▶ Compact design for tight installation conditions
- ▶ Optional through drive for mounting additional pumps

Contents

| | |
|--|----|
| Type code | 2 |
| Hydraulic fluids | 5 |
| Working pressure range | 6 |
| Technical data | 8 |
| EP – Proportional control, electric | 10 |
| Dimensions, size 85–85 | 12 |
| Dimensions, size 110–110 | 14 |
| Dimensions, size 125–125 | 16 |
| Dimensions, through drive | 18 |
| Overview of mounting options | 21 |
| High-pressure relief valves | 22 |
| Pressure cut-off | 23 |
| Mechanical stroke limiter | 24 |
| Stroking chamber pressure port X ₃ and X ₄ | 25 |
| Filtration boost circuit / external boost pressure supply | 26 |
| Connector for solenoids | 27 |
| Swivel angle sensor | 28 |
| Installation dimensions for coupling assembly | 29 |
| Installation instructions | 30 |
| Project planning notes | 33 |
| Safety instructions | 34 |

Type code

| | | | | | | | | | | | | | | | | | |
|-------------|----------|----|----|----|----|----|----|----|----|-----------|----|----|----|----|----|----|----|
| 01 | 02 | 03 | 04 | 05 | 06 | 07 | 08 | 09 | 10 | 11 | 12 | 13 | 14 | 15 | 16 | 17 | 18 |
| A24V | G | | | | | | | | / | 10 | | | | | | | - |

Axial piston unit

| | | |
|----|---|-------------|
| 01 | Swashplate design, variable, nominal pressure 450 bar, maximum pressure 500 bar | A24V |
|----|---|-------------|

Operating mode

| | | |
|----|-------------------------------|----------|
| 02 | Double pump in closed circuit | G |
|----|-------------------------------|----------|

Size (NG)

| | | | |
|----|--|--------|----------------|
| 03 | Geometric displacement, see "Technical data" on page 8 | | |
| | Pump 1 | Pump 2 | |
| | NG85 | NG85 | 085-085 |
| | NG110 | NG85 | 110-085 |
| | NG110 | NG110 | 110-110 |
| | NG125 | NG85 | 125-085 |
| | NG125 | NG110 | 125-110 |
| | NG125 | NG125 | 125-125 |

Control device pump 1

085...125

| | | | | |
|----|--------------------------------|----------------------|-------------------|------------|
| 04 | Proportional control, electric | $U = 12\text{ V}$ | ● | EP1 |
| | | $U = 24\text{ V}$ | ● | EP2 |
| | | with manual override | ● | EP3 |
| | | and spring return | $U = 12\text{ V}$ | ● |
| | | $U = 24\text{ V}$ | ● | EP4 |

Control device pump 2

085...125

| | | | | |
|----|--------------------------------|----------------------|-------------------|------------|
| 05 | Proportional control, electric | $U = 12\text{ V}$ | ● | EP1 |
| | | $U = 24\text{ V}$ | ● | EP2 |
| | | with manual override | ● | EP3 |
| | | and spring return | $U = 12\text{ V}$ | ● |
| | | $U = 24\text{ V}$ | ● | EP4 |

Pressure cut-off

| | | | | |
|----|---------------------------------|---------------------------------|--------------------------|----------|
| 06 | Pump 1 | Pump 2 | 085...125 | |
| | | Without pressure cut-off | Without pressure cut-off | ● |
| | Pressure cut-off, fixed setting | Without pressure cut-off | ● | L |
| | | Pressure cut-off, fixed setting | Without pressure cut-off | ● |
| | | Pressure cut-off, fixed setting | ● | R |

Swivel angle sensor

085 110 125

| | | | | | |
|----|---|-----------------|-----------------|-----------------|----------|
| 07 | Without swivel angle sensor | ● | ● | ● | 0 |
| | Electric swivel angle sensor mounted (DWS20-1, 3-pin) ¹⁾ | ● ²⁾ | ● ²⁾ | ● ²⁾ | T |

Additional function pump 1

085 110 125

| | | | | | |
|----|--|---|---|---|----------|
| 08 | Without additional function | ● | ● | ● | 0 |
| | Mechanical stroke limiter, externally adjustable | ● | ● | ● | M |
| | Stroking chamber pressure port X₃ , X₄ | ● | ● | ● | T |
| | Mechanical stroke limiter and stroking chamber pressure port X₃ , X₄ | ● | ● | ● | B |

● = Available ○ = On request - = Not available = Preferred program

¹⁾ Please contact us if the swivel angle sensor is used for control

²⁾ Available with E4 flange and in combination without through drive. For other versions, please contact us.

| | | | | | | | | | | | | | | | | | | |
|-------------|----------|----|----|----|----|----|----|----|----|-----------|----|----|----|----|----|----|----|--|
| 01 | 02 | 03 | 04 | 05 | 06 | 07 | 08 | 09 | 10 | 11 | 12 | 13 | 14 | 15 | 16 | 17 | 18 | |
| A24V | G | | | | | | | | / | 10 | | | | | | | - | |

| | | 085 | 110 | 125 | |
|----|--|-----|-----|-----|---|
| 09 | Without additional function | ● | ● | ● | 0 |
| | Mechanical stroke limiter, externally adjustable | ● | ● | ● | M |
| | Stroking chamber pressure port X₃ , X₄ | ● | ● | ● | T |
| | Mechanical stroke limiter and stroking chamber pressure port X₃ , X₄ | ● | ● | ● | B |

| | | 085 | 110 | 125 | |
|----|-----------------------------|-----|-----|-----|---|
| 10 | Without additional function | ● | ● | ● | 0 |

| Series | | | | | |
|--------|-------------------|--|--|--|----|
| 11 | Series 1, index 0 | | | | 10 |

| | | 085 | 110 | 125 | |
|----|---|-----|-----|-----|---|
| 12 | Metric ports according to ISO 6149 with O-ring seal metric fastening thread according to DIN 13 | ● | ● | ● | M |
| | Ports according to ISO 11926 with O-ring seal (ANSI), metric fastening thread according to DIN 13 at the working port and at the through drive | ● | ● | ● | D |

| | | 085 | 110 | 125 | | |
|----|-----------------------|-------------------|-----|-----|---|---|
| 13 | Viewed on drive shaft | clockwise | ● | ● | ● | R |
| | | counter-clockwise | ● | ● | ● | L |

| | | 085 | 110 | 125 | | |
|----|----------|---------|-----|-----|---|----|
| 14 | SAE J744 | 152-2/4 | ● | ● | ● | D6 |
| | | 165-4 | ● | ● | ● | E4 |

| | | 085 | 110 | 125 | | |
|----|-----------------------------------|---------------------|-----|-----|---|----|
| 15 | Splined shaft ANSI B92.1a-1976 | 1 3/4 in 13T 8/16DP | ● | ● | ● | T1 |
| | | 2 in 15T 8/16DP | ● | ● | ● | T2 |

| | | 085 | 110 | 125 | | | | | |
|----------------------|-----------------------|-------------------------------------|------|----------------------|------|---|---|------|------|
| 16 | Without through drive | ● | ● | ● | 0000 | | | | |
| | Flange SAE J744 | Hub for splined shaft ³⁾ | | | | | | | |
| | Diameter | Mounting ⁴⁾ | Code | Diameter | Code | | | | |
| | 101-2 (B) | ⌀ | B1 | 7/8 in 13T 16/32DP | S4 | - | - | ○ | B1S4 |
| | | | | 1 in 15T 16/32DP | S5 | - | - | ○ | B1S5 |
| | ∞ | ∞ | B2 | 7/8 in 13T 16/32DP | S4 | - | - | ● | B2S4 |
| | | | | 1 in 15T 16/32DP | S5 | - | - | ● | B2S5 |
| | 127-2 (C) | ⌀ | C1 | 1 3/8 in 21T 16/32DP | V8 | ● | ● | ● | C1V8 |
| | | | | 1 1/4 in 14T 12/24DP | S7 | ● | ● | ● | C2S7 |
| | 127-4 (C) | ⌀ | C4 | 1 1/4 in 14T 12/24DP | S7 | ● | ● | ● | C4S7 |
| 1 3/8 in 21T 16/32DP | | | | V8 | ● | ● | ● | C4V8 | |

● = Available ○ = On request - = Not available = Preferred program

³⁾ Hub for splined shaft according to ANSI B92.1a (drive shaft allocation according to SAE J744)

⁴⁾ Mounting holes pattern viewed on through drive with control at top

4 **A24VG series 10** | Axial piston variable double pump
Type code

| | | | | | | | | | | | | | | | | | | |
|-------------|----------|----|----|----|----|----|----|----|----|----|-----------|----|----|----|----|----|----|--|
| 01 | 02 | 03 | 04 | 05 | 06 | 07 | 08 | 09 | 10 | 11 | 12 | 13 | 14 | 15 | 16 | 17 | 18 | |
| A24V | G | | | | | | | | | / | 10 | | | | | | - | |

Selection of other features

| 17 | | | | B2 | B3 |
|----|--|--------|---|----|----|
| | Connector control module ⁵⁾ | Pump 1 | DEUTSCH molded connector 2-pin, DT04-2P – without suppressor diode | • | • |
| | | Pump 2 | DEUTSCH molded connector 2-pin, DT04-2P – without suppressor diode | • | • |
| | Sealing material | | NBR (nitrile rubber), shaft seal made of FKM (fluoroelastomer) | • | • |
| | Working port | | SAE working port A and B, same side left | • | - |
| | | | SAE working port A and B, same side right | - | • |
| | High-pressure relief valve HD | Pump 1 | Direct operated, fixed setting, without bypass | • | • |
| | | Pump 2 | Direct operated, fixed setting, without bypass | • | • |
| | Low-pressure relief valve ND | | Fixed setting | • | • |
| | Pressure sensor | Pump 1 | Without pressure sensor | • | • |
| | | Pump 2 | Without pressure sensor | • | • |
| | Speed sensor | | Without speed sensor | • | • |

Standard/special version

| 18 | | |
|----|---|---|
| | Standard version | 0 |
| | Standard version with installation variants e. g. T ports against standard open or closed | Y |
| | Special version | S |

• = Available ◦ = On request - = Not available = Preferred program

Notice

- ▶ Note the project planning notes on page 33.
- ▶ In addition to the type code, please specify the relevant technical data when placing your order.
- ▶ Please note that not all type code combinations are available although the individual functions are marked as being available.

⁵⁾ Connectors for other electric components may deviate

Hydraulic fluids

The axial piston unit is designed for operation with HLP mineral oil according to DIN 51524.

Application instructions and requirements for hydraulic fluid selection, behavior during operation as well as disposal and environmental protection should be taken from the following data sheets before the start of project planning:

- ▶ 90220: Hydraulic fluids based on mineral oils and related hydrocarbons
- ▶ 90221: Environmentally acceptable hydraulic fluids
- ▶ 90222: Fire-resistant, water-free hydraulic fluids (HFDR/HFDU)

Selection of hydraulic fluid

Bosch Rexroth evaluates hydraulic fluids on the basis of the Fluid Rating according to the technical data sheet 90235.

Hydraulic fluids with positive evaluation in the Fluid Rating are provided in the following technical data sheet:

- ▶ 90245: Bosch Rexroth Fluid Rating List for Rexroth hydraulic components (pumps and motors)

Selection of hydraulic fluid shall make sure that the operating viscosity in the operating temperature range is within the optimum range (v_{opt} see selection diagram).

Viscosity and temperature of hydraulic fluids

| | Viscosity | Shaft seal | Temperature ³⁾ | Comment |
|----------------------|---|-------------------|---|---|
| Cold start | $v_{max} \leq 1600 \text{ mm}^2/\text{s}$ | NBR ²⁾ | $\theta_{st} \geq -40 \text{ }^\circ\text{C}$ | $t \leq 3\text{min}$, without load ($p \leq 50 \text{ bar}$), $n \leq 1000 \text{ rpm}$ Permissible temperature difference between axial piston unit and hydraulic fluid in the system maximum 25 K |
| | | FKM | $\theta_{st} \geq -25 \text{ }^\circ\text{C}$ | |
| Warm-up phase | $v = 1600 \dots 400 \text{ mm}^2/\text{s}$ | | | $t \leq 15\text{min}$, $p \leq 0.7 \times p_{nom}$ and $n \leq 0.5 \times n_{nom}$ |
| Continuous operation | $v = 400 \dots 10 \text{ mm}^2/\text{s}^1)$ | NBR ²⁾ | $\theta \leq +85 \text{ }^\circ\text{C}$ | Measured at port T |
| | | FKM | $\theta \leq +110 \text{ }^\circ\text{C}$ | |
| | $v_{opt} = 36 \dots 16 \text{ mm}^2/\text{s}$ | | | Optimal operating viscosity and efficiency range |
| Short-term operation | $v_{min} = 10 \dots 7 \text{ mm}^2/\text{s}$ | NBR ²⁾ | $\theta \leq +85 \text{ }^\circ\text{C}$ | $t \leq 3\text{min}$, $p \leq 0.3 \times p_{nom}$, measured at port T |
| | | FKM | $\theta \leq +110 \text{ }^\circ\text{C}$ | |

Notice

The maximum circuit temperature of +115 °C must not be exceeded at working ports A and B, while maintaining the permissible viscosity.

▼ Selection diagram

Maximum permissible viscosity on cold start

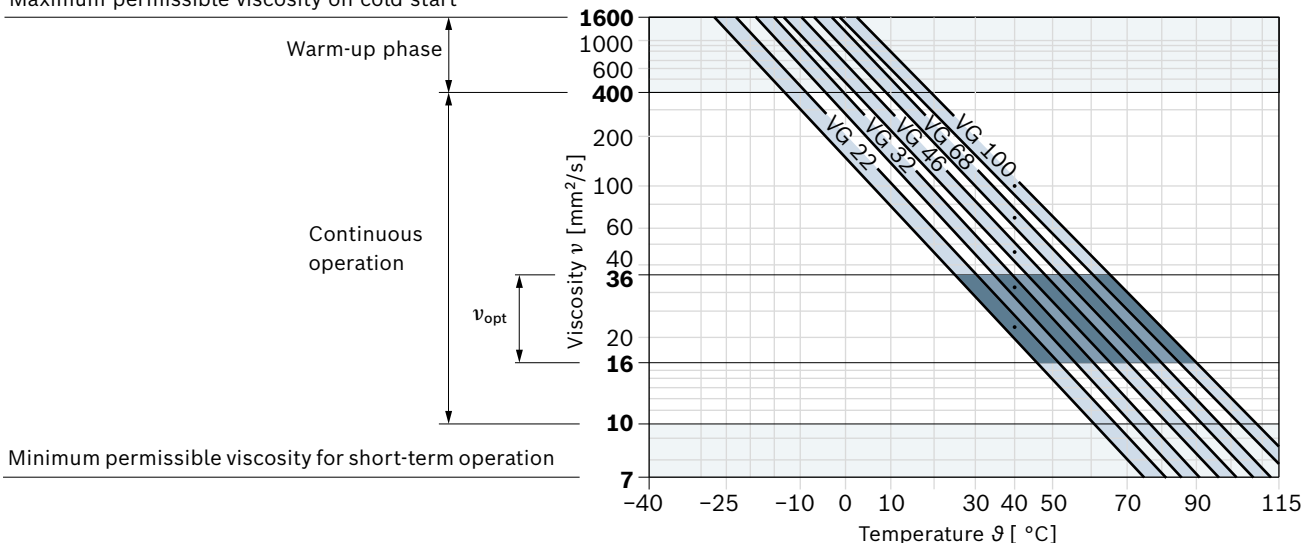

1) This corresponds, for example on the VG 46, to a temperature range of +4 °C to +85 °C (see selection diagram)

2) Special version, please contact us

3) If the temperature at extreme operating parameters cannot be adhered to, please contact us.

Filtration of the hydraulic fluid

Finer filtration improves the cleanliness level of the hydraulic fluid, which increases the service life of the axial piston unit.

A cleanliness level of at least 20/18/15 is to be maintained according to ISO 4406.

At a hydraulic fluid viscosity of less than 10 mm²/s (e.g. due to high temperatures during short-term operation), a cleanliness level of at least 19/17/14 under ISO 4406 is required.

For example, the viscosity corresponds to 10 mm²/s at:

- ▶ HLP 32 a temperature of 73°C
- ▶ HLP 46 a temperature of 85°C

Working pressure range

| Pressure at working port A or B | | Definition | |
|---|-----------------------------|--|----------------------------|
| Nominal pressure p_{nom} | 450 bar | The nominal pressure corresponds to the maximum design pressure. | |
| Maximum pressure p_{max} | 500 bar | The maximum pressure corresponds to the maximum working pressure within a single operating period. The sum of single operating periods must not exceed the total operating period. | |
| Single operating period | 10 s | | |
| Total operating period | 300 h | | |
| Minimum pressure (low-pressure side) | 10 bar over Case pressure | Minimum pressure on the low-pressure side (A or B) required to prevent damage to the axial piston unit. Boost pressure setting must be higher depending on system. | |
| Rate of pressure change $R_{A max}$ | 9000 bar/s | Maximum permissible pressure build-up and reduction speed during a pressure change across the entire pressure range. | |
| Control pressure | | Definition | |
| Minimum control pressure $p_{St min}$ at $n = 2000$ rpm | | Required control pressure p_{St} , to ensure the function of the control. The required control pressure is dependent on rotational speed, working pressure and the spring assembly of the stroking piston. | |
| | NG85 to 110: | | NG125: |
| Control EP | 20 bar above case pressure | | 25 bar above case pressure |
| Case pressure at port T | | Definition | |
| Continuous differential pressure $\Delta p_{T cont}$ | 2 bar | Maximum averaged differential pressure at the shaft seal (housing to ambient pressure) | |
| Maximum differential pressure $\Delta p_{T max}$ | See the diagram (next page) | Permissible differential pressure at the shaft seal (housing to ambient pressure) | |
| Pressure peaks $p_{T peak}$ | 10 bar | $t < 0.1$ s, maximum 1000 pressure peaks permissible | |

▼ **Maximum pressure p_{max} up to 500 bar and total operating period**

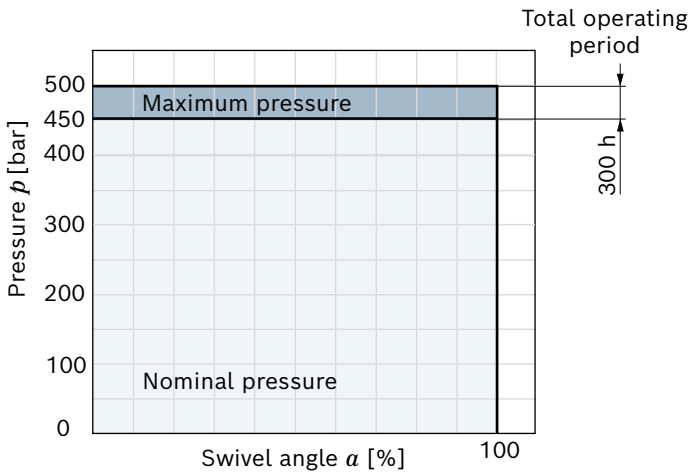

▼ **Rate of pressure change R_{Amax}**

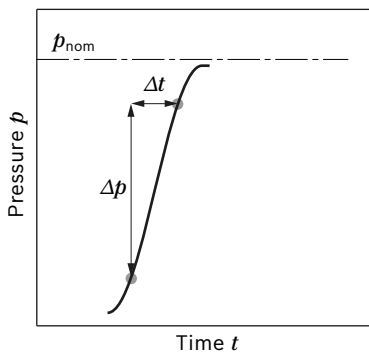

▼ **Maximum differential pressure at the shaft seal**

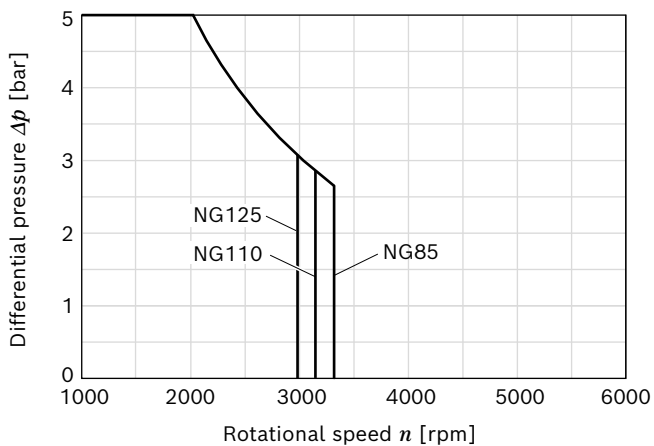

▼ **Pressure definition**

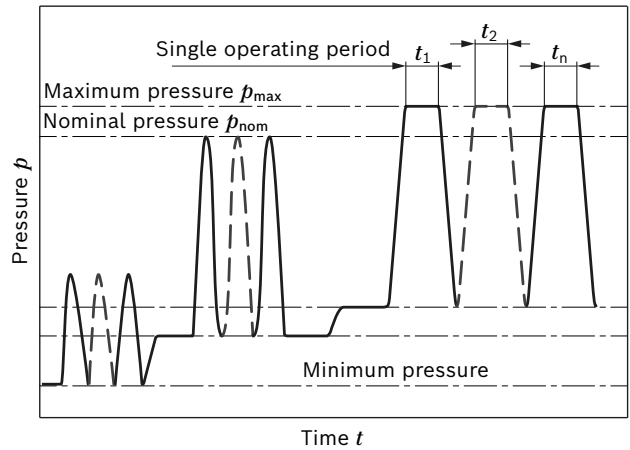

Total operating period = $t_1 + t_2 + \dots + t_n$

Notice

- ▶ Working pressure range applies when using hydraulic fluids based on mineral oils. Please contact us for values for other hydraulic fluids.
- ▶ In addition to the hydraulic fluid and the temperature, the service life of the shaft seal is influenced by the rotational speed of the axial piston unit and the case pressure.
- ▶ The service life of the shaft seal decreases with increasing frequency of pressure peaks and increasing mean differential pressure.
- ▶ The case pressure must be greater than the external pressure (ambient pressure) at the shaft seal ring.

Technical data

| Size | | NG | | 85-85 | 110-110 | 125-125 |
|--|---|----------------------|--------------------|---------|---------|---------|
| Geometric displacement, per revolution | Pump 1 | $V_{g \max}$ | cm ³ | 85.4 | 110.4 | 125 |
| | Pump 2 | $V_{g \max}$ | cm ³ | 85.4 | 110.4 | 125 |
| Rotational speed ¹⁾ | maximum at $V_{g \max}$ | n_{nom} | rpm | 3300 | 3150 | 3000 |
| | at $\Delta p \geq 40$ bar ($t < 15$ s) | $n_{\text{max } 40}$ | rpm | 3500 | 3350 | 3200 |
| | minimum | n_{min} | rpm | 500 | 500 | 500 |
| Flow | at $V_{g \max}$ | Pump 1 | q_v | l/min | 280,5 | 346.5 |
| | and n_{nom} | Pump 2 | q_v | l/min | 280,5 | 346.5 |
| Power | at $V_{g \max}$, n_{nom} and $\Delta p = 430$ bar | P | kW | 402 | 496 | 537 |
| Torque | with $V_{g \max}$ and | $\Delta p = 430$ bar | M | Nm | 1164 | 1506 |
| | | $\Delta p = 100$ bar | M | Nm | 271 | 350 |
| Rotary stiffness Drive shaft | 1 3/4 in T1 | Pump 1 | c1 | kNm/rad | 214 | 214 |
| | | Pump 2 | c2 | kNm/rad | 45.6 | 45.6 |
| | 2 in T2 | Pump 1 | c1 | kNm/rad | 246.3 | 246.3 |
| | | Pump 2 | c2 | kNm/rad | 45.6 | 45.6 |
| Moment of inertia (see graphic below) | Rotary group 1 | J_{TW1} | kgm ² | 0.02177 | 0.02177 | |
| | Rotary group 2 | J_{TW2} | kgm ² | 0.02177 | 0.02177 | |
| Maximum angular acceleration for each rotary group ²⁾ | | α | rad/s ² | 14500 | 14500 | |
| Case volume | | V | l | 5.1 | 5.1 | |
| Weight (without through drive) approx. ³⁾ | | m | kg | 155.4 | 155.4 | |

Case volume and weight when combining different sizes

| Size | NG | | 110-85 | 125-85 | 125-110 |
|--|----|-----|--------|--------|---------|
| Case volume | | V | l | 5.6 | 5.6 |
| Weight (without through drive) approx. ³⁾ | | m | kg | 155.4 | 155.4 |

▼ Spring mass system at moment of inertia

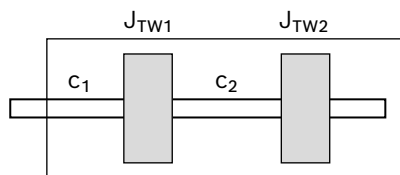

- 1) The values are applicable:
 - for the optimum viscosity range from $\nu_{\text{opt}} = 36$ to $16 \text{ mm}^2/\text{s}$
 - with hydraulic fluid based on mineral oils
- 2) The data are valid for values between the minimum required and maximum permissible rotational speed. Valid for external excitation (e. g. diesel engine 2 to 8 times rotary frequency; cardan shaft twice the rotary frequency). The limit value is only valid for a single pump. The load capacity of the connection parts must be considered.
- 3) Weight may vary by equipment

Notice

- ▶ Theoretical values, without efficiency and tolerances; values rounded
- ▶ Operation above the maximum values or below the minimum values may result in a loss of function, a reduced service life or in the destruction of the axial piston unit. Bosch Rexroth recommends testing the loads by means of experiment or calculation / simulation and comparison with the permissible values.
- ▶ When combining different sizes, the rotational speed of the larger size applies. This is the basis for calculating flow, power and torque.

| Determination of the operating characteristics | | |
|--|---|---------|
| Flow | $q_v = \frac{V_g \times n \times \eta_v}{1000}$ | [l/min] |
| Torque | $M = \frac{V_g \times \Delta p}{20 \times \pi \times \eta_{mh}}$ | [Nm] |
| Power | $P = \frac{2 \pi \times T \times n}{60000} = \frac{q_v \times \Delta p}{600 \times \eta_t}$ | [kW] |

| | |
|-------------|---|
| Key | |
| V_g | Displacement per revolution [cm ³] |
| Δp | Differential pressure [bar] |
| n | Rotational speed [rpm] |
| η_v | Volumetric efficiency |
| η_{mh} | Mechanical-hydraulic efficiency |
| η_t | Total efficiency ($\eta_t = \eta_v \times \eta_{mh}$) |

Permissible radial and axial loading of the drive shaft

| Size | NG | 85 | 85 | 110 | 110 | 125 | 125 | |
|--|-----------------|-------|------|-------|------|-------|------|------|
| Drive shaft | in | 1 3/4 | 2 | 1 3/4 | 2 | 1 3/4 | 2 | |
| Maximum radial force at distance a (to the shaft collar) | $F_{q \max}$ | N | 7483 | 6548 | 7483 | 6548 | 6500 | 6658 |
| | a | mm | 33.5 | 40 | 33.5 | 40 | 33.5 | 40 |
| Maximum axial force | $+ F_{ax \max}$ | N | 6305 | 6305 | 6305 | 6305 | 6411 | 6411 |
| | $- F_{ax \max}$ | N | 4095 | 4095 | 4095 | 4095 | 3989 | 3989 |

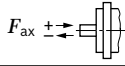

Notice

- ▶ The axial and radial loading generally influence the bearing service life.
- ▶ Special requirements apply in the case of belt drive and cardan shaft. Please contact us.

Permissible input and through-drive torques

| Size | NG | 85-85 | 110-85 | 110-110 | 125-85 | 125-110 | 125-125 | |
|--|-----------------|-------|---|----------|----------|----------|----------|----------|
| Torque at $V_{g \max}$ and $\Delta p = 430 \text{ bar}^{1)}$ | $M = M_1 + M_2$ | Nm | 584+ 584 | 756+ 584 | 756+ 756 | 856+ 584 | 856+ 756 | 856+ 856 |
| Maximum input torque at drive shaft ²⁾ | | | | | | | | |
| T1 1 3/4 in | $M_{E \max}$ | Nm | 1640 | 1640 | 1640 | 1640 | 1640 | 1640 |
| T2 2 in | $M_{E \max}$ | Nm | 2670 | 2670 | 2670 | 2670 | 2670 | 2670 |
| Maximum through-drive torque | $M_{D1 \max}$ | Nm | 934 | 934 | 934 | 1110 | 1110 | 1110 |
| | $M_{D2 \max}$ | Nm | $M_{D2 \text{ perm}} = M_{D1 \max} - M_2$ | | | | | |

▼ Distribution of torques

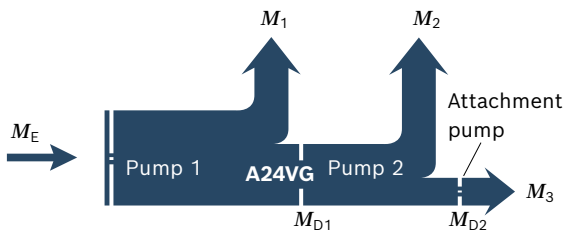

| | | |
|------------------------|-------------------------|-------|
| Torque A24VG | 1st pump | M_1 |
| | 2. pump | M_2 |
| Torque attachment pump | M_3 | |
| Input torque | $M_E = M_1 + M_2 + M_3$ | |
| | $M_E < M_{E \max}$ | |
| Through-drive torque | M_{D1} | |
| | M_{D2} | |

1) Efficiency not considered
 2) For drive shafts free of radial force

EP – Proportional control, electric

The output flow of the pump is infinitely variable between 0 and 100%, proportional to the electrical current supplied to solenoid **a** or **b**.

The electrical energy is converted into a force acting on the control spool.

This control spool then directs control oil into and out of the stroking cylinder to adjust pump displacement as required.

A feedback lever connected to the stroking piston maintains the pump flow for any given current within the control range.

▼ Size 85

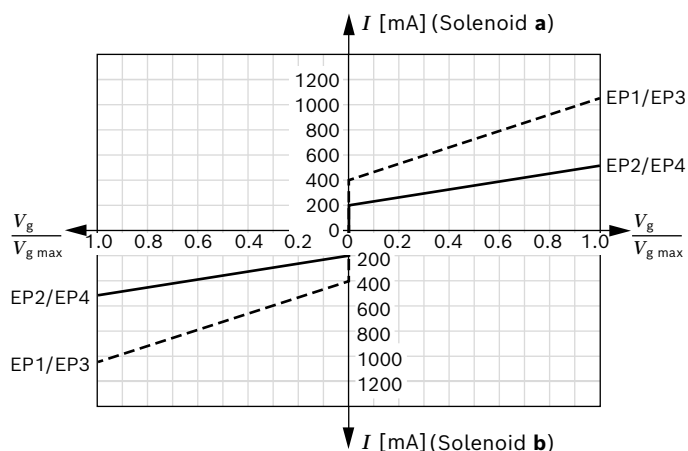

▼ Size 110 and 125

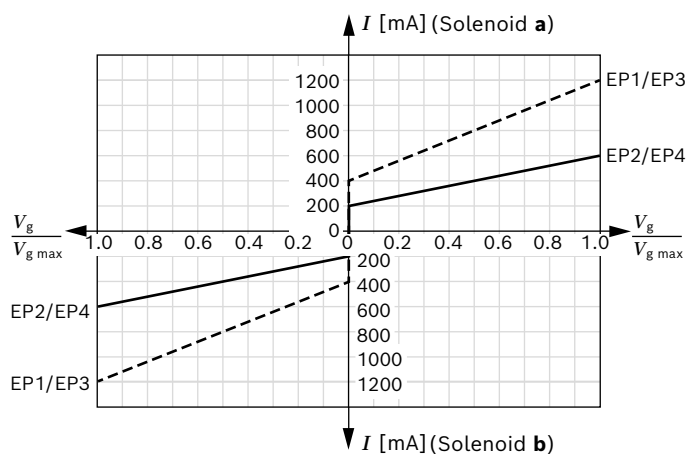

| Technical data, Proportional solenoid | EP1/EP3 | EP2/EP4 |
|---|---------------------|---------------------|
| Voltage | 12 V ($\pm 20\%$) | 24 V ($\pm 20\%$) |
| Current limit | 1.54 A | 0.77 A |
| Nominal resistance (at 20 °C) | 5.5 Ω | 22.7 Ω |
| Dither | | |
| frequency | 100 Hz | 100 Hz |
| minimum oscillation range ¹⁾ | 240 mA | 120 mA |
| Duty cycle | 100% | 100% |
| Type of protection: see connector version page 27 | | |

Control current

| EP1/EP3 | NG | 85 | 110 | 125 |
|--------------------------------|----|------|------|------|
| Start of control at $V_g = 0$ | mA | 400 | 400 | 400 |
| End of control at $V_{g \max}$ | mA | 1040 | 1200 | 1200 |
| EP2/EP4 | NG | 85 | 110 | 125 |
| Start of control at $V_g = 0$ | mA | 200 | 200 | 200 |
| End of control at $V_{g \max}$ | mA | 520 | 600 | 600 |

Various BODAS controllers with application software and amplifiers are available for controlling the proportional solenoids.

Further information can also be found on the Internet at www.boschrexroth.com/mobile-electronics.

▼ Circuit diagram with manual override and spring return

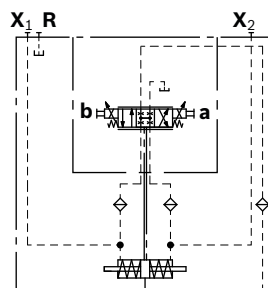

Notice

The proportional solenoids in version EP1/EP2 do not have manual override. Proportional solenoids with manual override and spring return are available on request (version EP3/EP4).

1) Minimum required oscillation range of the control current ΔI_{p-p} (peak to peak) within the respective control range (start of control to end of control)

Correlation of direction of rotation, control and flow direction

| Direction of rotation | clockwise | | | | counter-clockwise | | | |
|-----------------------|----------------------|----------------------|----------------------|----------------------|----------------------|----------------------|----------------------|----------------------|
| | Pump 1 | | Pump 2 | | Pump 1 | | Pump 2 | |
| Actuation of solenoid | a | b | a | b | a | b | a | b |
| Control pressure | X₂ | X₁ | X₂ | X₁ | X₂ | X₁ | X₂ | X₁ |
| Flow direction | A to B | B to A | B to A | A to B | B to A | A to B | A to B | B to A |
| Working pressure | M_B | M_A | M_A | M_B | M_A | M_B | M_B | M_A |

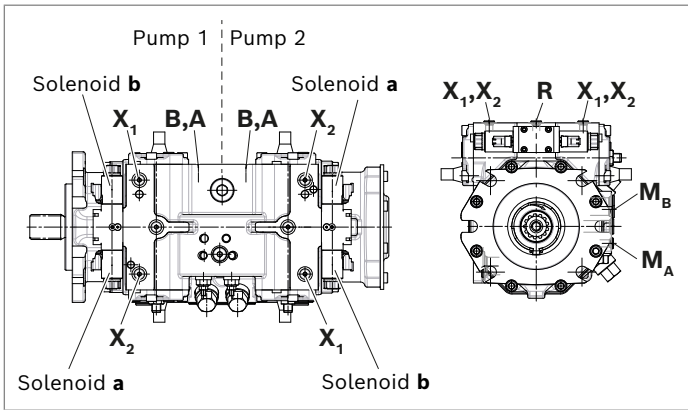

▼ **Circuit diagram**

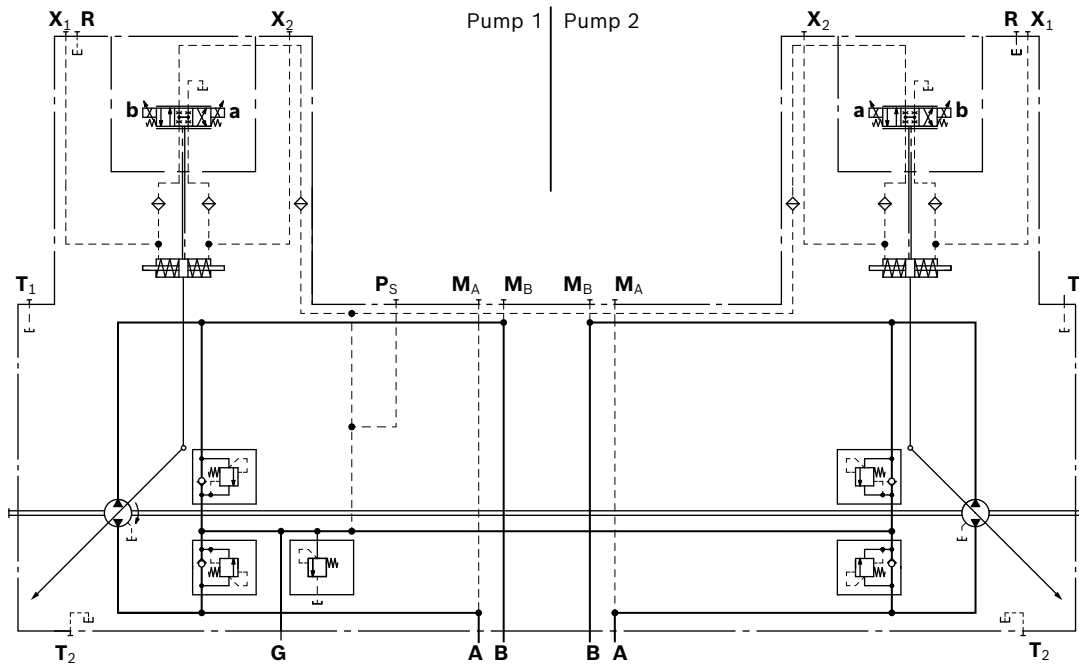

Dimensions, size 85–85

EP – Proportional control, electric

SAE working ports A and B, same side left (viewed on drive shaft)¹⁾

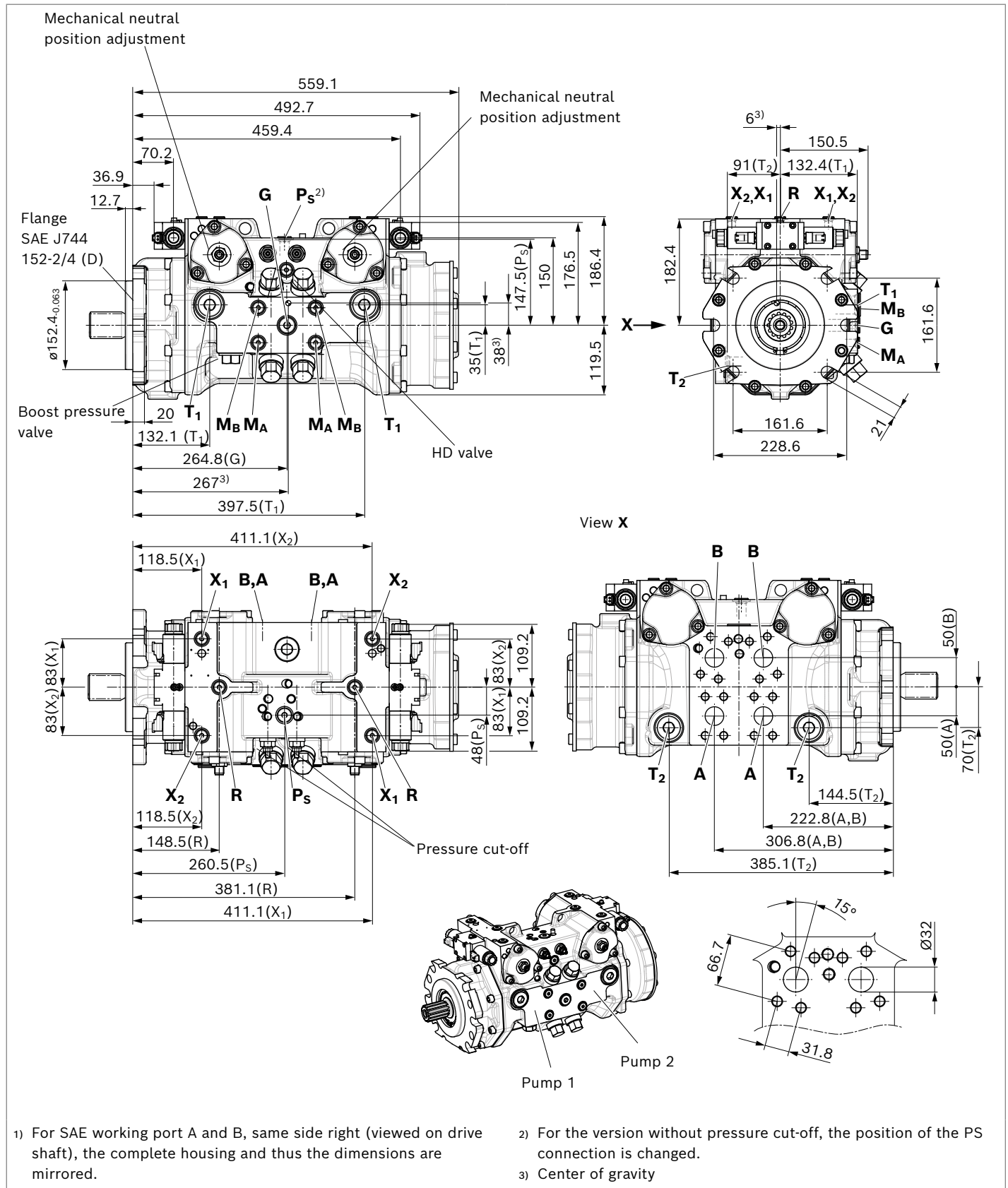

1) For SAE working port A and B, same side right (viewed on drive shaft), the complete housing and thus the dimensions are mirrored.

2) For the version without pressure cut-off, the position of the P_s connection is changed.

3) Center of gravity

▼ Splined shaft ANSI B92.1a

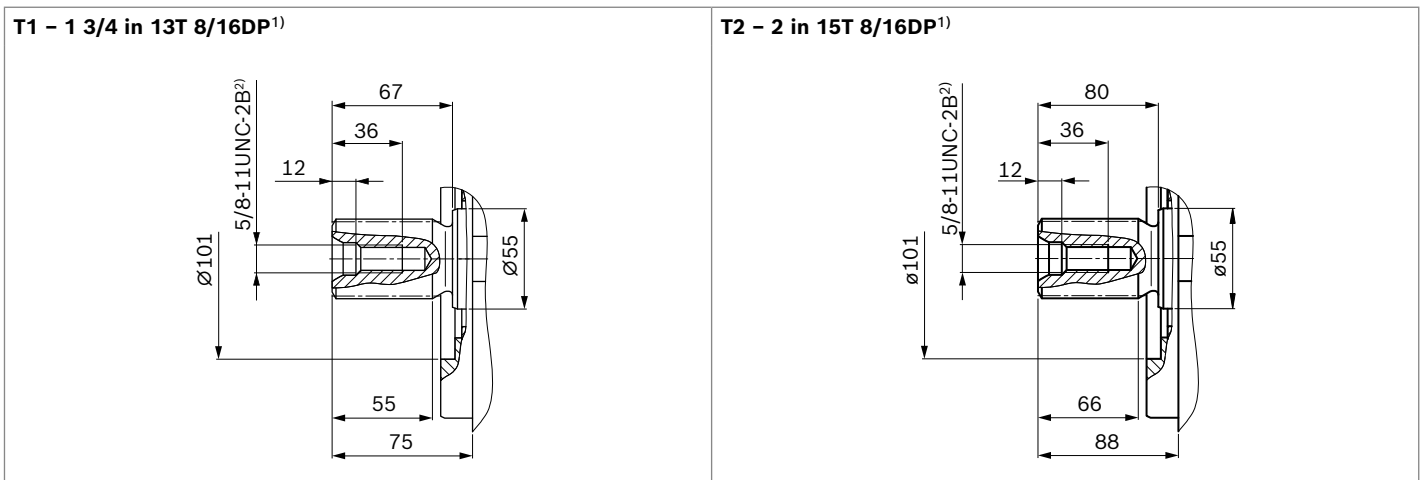

| Ports version "M", metric | | Standard | Size | p_{\max} [bar] ³⁾ | State ⁹⁾ | |
|--|---|---------------------------------|----------------------------------|--------------------------------|---------------------|-----------------|
| | | | | | Pump 1 | Pump 2 |
| A, B | Working port Fastening thread | SAEJ518 ⁴⁾ DIN 13 | 1 1/4 in M14 × 2; 19 deep | 500 | O | O |
| T₁ | Drain port | ISO 6149 ⁵⁾ | M27 × 2; 19 deep | 3 | X ⁶⁾ | X ⁶⁾ |
| T₂ | Drain port | ISO 6149 ⁵⁾ | M27 × 2; 19 deep | 3 | X ⁶⁾ | O ⁶⁾ |
| R | Air bleed port | ISO 6149 ⁵⁾ | M14 × 1.5; 11.5 deep | 3 | X | X |
| X₁, X₂ | Control pressure port (upstream of orifice) | ISO 6149 ⁵⁾ | M14 × 1.5; 11.5 deep | 40 | X | X |
| X₃, X₄⁷⁾ | Stroking chamber pressure port | ISO 6149 ⁵⁾ | M14 × 1.5; 11.5 deep | 40 | X | X |
| G | Boost pressure port inlet | ISO 6149 ⁵⁾ | M22 × 1.5; 17 deep | 40 | | O |
| P_S | Pilot pressure port inlet | ISO 6149 ⁵⁾ | M18×1.5; 14.5 deep ⁸⁾ | 40 | | X |
| M_A, M_B | Measuring port pressure A, B | ISO 6149 ⁵⁾ | M14 × 1.5; 11.5 deep | 500 | X | X |

| Ports version "D", ANSI, metric fastening thread | | Standard | Size | p_{\max} [bar] ³⁾ | State ⁹⁾ | |
|--|---|---------------------------------|--|--------------------------------|---------------------|-----------------|
| | | | | | Pump 1 | Pump 2 |
| A, B | Working port Fastening thread | SAEJ518 ⁴⁾ DIN 13 | 1 1/4 in M14 × 2; 19 deep | 500 | O | O |
| T₁ | Drain port | ISO 11926 ⁵⁾ | 1 1/16 -12 UN-2B; 20 deep | 3 | X ⁶⁾ | X ⁶⁾ |
| T₂ | Drain port | ISO 11926 ⁵⁾ | 1 1/16 -12 UN-2B; 20 deep | 3 | X ⁶⁾ | O ⁶⁾ |
| R | Air bleed port | ISO 11926 ⁵⁾ | 9/16 -18 UNF-2B; 13 deep | 3 | X | X |
| X₁, X₂ | Control pressure port (upstream of orifice) | ISO 11926 ⁵⁾ | 9/16 -18 UNF-2B; 13 deep | 40 | X | X |
| X₃, X₄⁷⁾ | Stroking chamber pressure port | ISO 11926 ⁵⁾ | 9/16 -18 UNF-2B; 13 deep | 40 | X | X |
| G | Boost pressure port inlet | ISO 11926 ⁵⁾ | 7/8 -14 UNF-2B; 17 deep | 40 | | O |
| P_S | Pilot pressure port inlet | ISO 11926 ⁵⁾ | 9/16 -18 UNF-2B; 13 deep ⁸⁾ | 40 | | X |
| M_A, M_B | Measuring port pressure A, B | ISO 11926 ⁵⁾ | 9/16 -18 UNF-2B; 13 deep | 500 | X | X |

1) Involute spline according to ANSI B92.1a, 30° pressure angle, flat root, side fit, tolerance class 5

2) Thread according to ASME B1.1

3) Depending on the application, momentary pressure peaks can occur. Keep this in mind when selecting measuring devices and fittings.

4) Only dimensions according to SAE J518, metric fastening thread is a deviation from the standard.

5) The countersink can be deeper than the standard. Ports designed for straight stud ends according to EN ISO 6149-2 or ISO 11926-2

6) Depending on installation position, T₁ or T₂ must be connected (see also installation instructions on page 30)

7) Optional, see page 25

8) Depending on function execution, the port size can vary

9) O = Must be connected (plugged on delivery)

X = Plugged (normal operation)

Dimensions, size 110–110

EP – Proportional control, electric

SAE working ports A and B, same side left (viewed on drive shaft)¹⁾

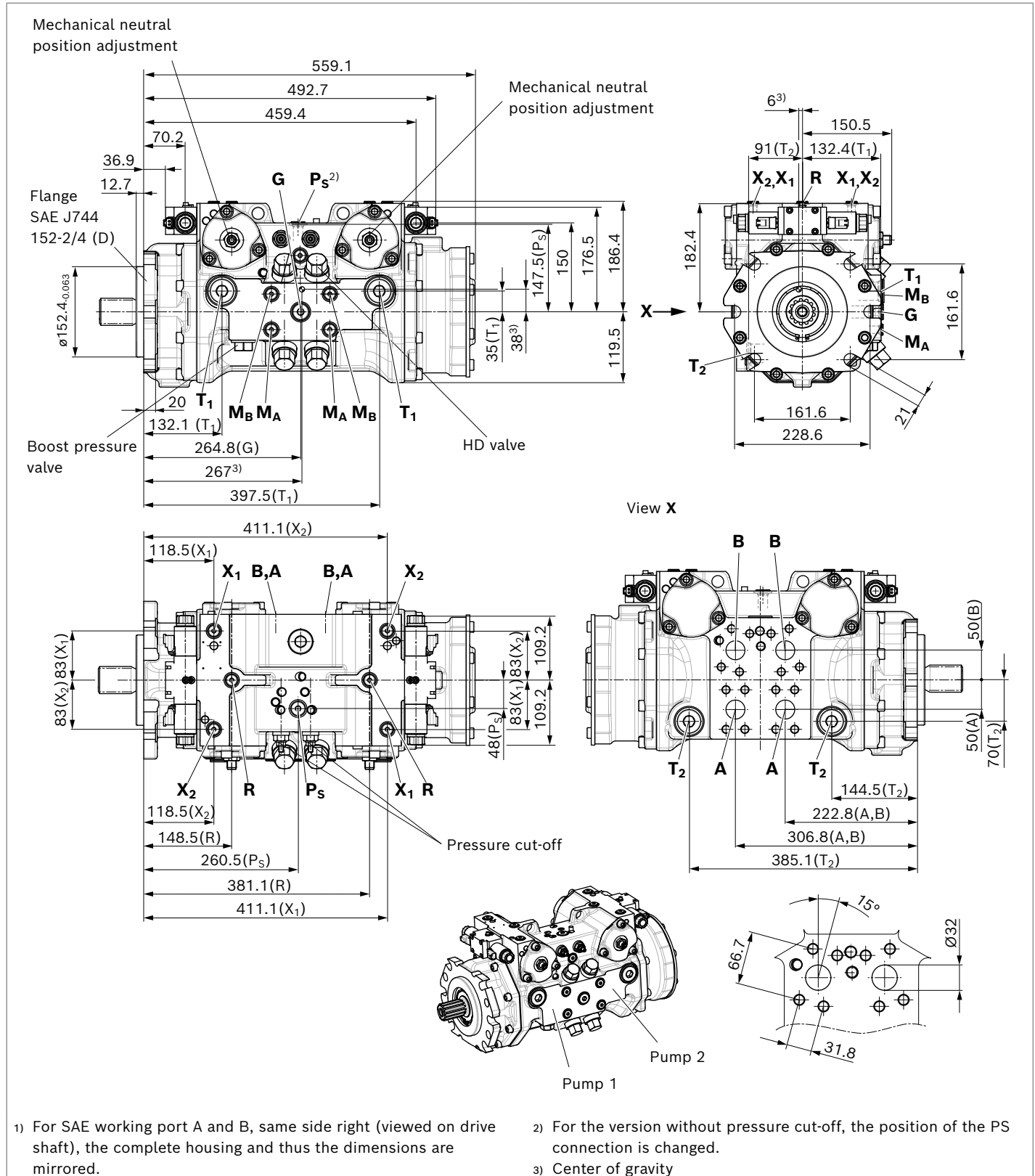

▼ Splined shaft ANSI B92.1a

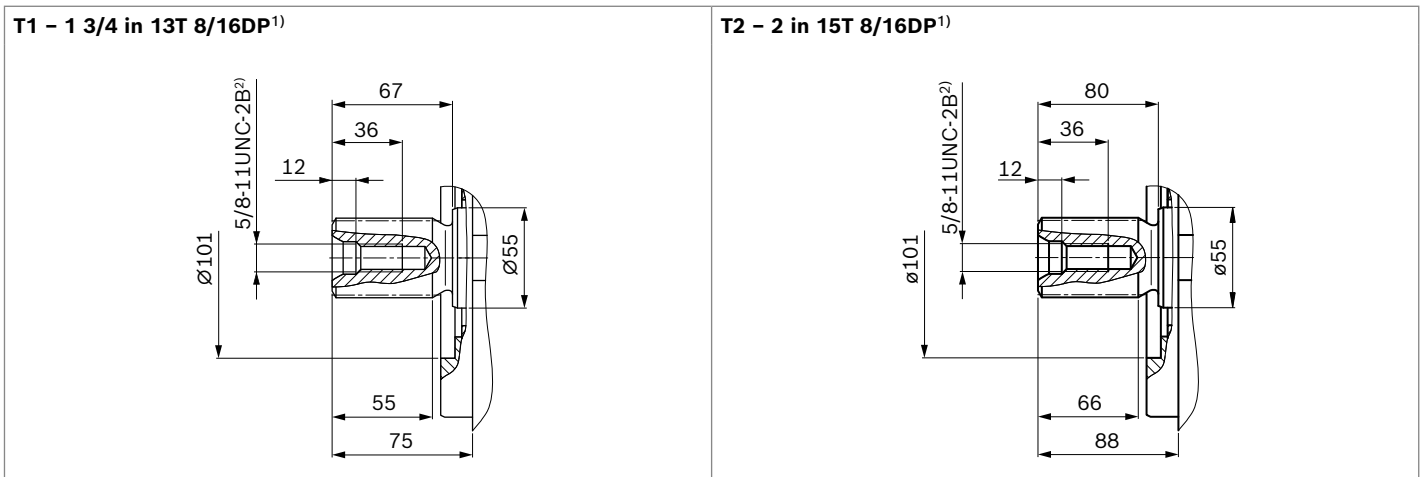

| Ports version "M", metric | | Standard | Size | p_{\max} [bar] ³⁾ | State ⁹⁾ | |
|---|---|---------------------------------|----------------------------------|--------------------------------|---------------------|-----------------|
| | | | | | Pump 1 | Pump 2 |
| A, B | Working port Fastening thread | SAEJ518 ⁴⁾ DIN 13 | 1 1/4 in M14 × 2; 19 deep | 500 | O | O |
| T₁ | Drain port | ISO 6149 ⁵⁾ | M27 × 2; 19 deep | 3 | X ⁶⁾ | X ⁶⁾ |
| T₂ | Drain port | ISO 6149 ⁵⁾ | M27 × 2; 19 deep | 3 | X ⁶⁾ | O ⁶⁾ |
| R | Air bleed port | ISO 6149 ⁵⁾ | M14 × 1.5; 11.5 deep | 3 | X | X |
| X₁, X₂ | Control pressure port (upstream of orifice) | ISO 6149 ⁵⁾ | M14 × 1.5; 11.5 deep | 40 | X | X |
| X₃, X₄ ⁷⁾ | Stroking chamber pressure port | ISO 6149 ⁵⁾ | M14 × 1.5; 11.5 deep | 40 | X | X |
| G | Boost pressure port inlet | ISO 6149 ⁵⁾ | M22 × 1.5; 17 deep | 40 | | O |
| P_S | Pilot pressure port inlet | ISO 6149 ⁵⁾ | M18×1.5; 14.5 deep ⁸⁾ | 40 | | X |
| M_A, M_B | Measuring port pressure A, B | ISO 6149 ⁵⁾ | M14 × 1.5; 11.5 deep | 500 | X | X |

| Ports version "D", ANSI, metric fastening thread | | Standard | Size | p_{\max} [bar] ³⁾ | State ⁹⁾ | |
|---|---|---------------------------------|--|--------------------------------|---------------------|-----------------|
| | | | | | Pump 1 | Pump 2 |
| A, B | Working port Fastening thread | SAEJ518 ⁴⁾ DIN 13 | 1 1/4 in M14 × 2; 19 deep | 500 | O | O |
| T₁ | Drain port | ISO 11926 ⁵⁾ | 1 1/16 -12 UN-2B; 20 deep | 3 | X ⁶⁾ | X ⁶⁾ |
| T₂ | Drain port | ISO 11926 ⁵⁾ | 1 1/16 -12 UN-2B; 20 deep | 3 | X ⁶⁾ | O ⁶⁾ |
| R | Air bleed port | ISO 11926 ⁵⁾ | 9/16 -18 UNF-2B; 13 deep | 3 | X | X |
| X₁, X₂ | Control pressure port (upstream of orifice) | ISO 11926 ⁵⁾ | 9/16 -18 UNF-2B; 13 deep | 40 | X | X |
| X₃, X₄ ⁷⁾ | Stroking chamber pressure port | ISO 11926 ⁵⁾ | 9/16 -18 UNF-2B; 13 deep | 40 | X | X |
| G | Boost pressure port inlet | ISO 11926 ⁵⁾ | 7/8 -14 UNF-2B; 17 deep | 40 | | O |
| P_S | Pilot pressure port inlet | ISO 11926 ⁵⁾ | 9/16 -18 UNF-2B; 13 deep ⁸⁾ | 40 | | X |
| M_A, M_B | Measuring port pressure A, B | ISO 11926 ⁵⁾ | 9/16 -18 UNF-2B; 13 deep | 500 | X | X |

1) Involute spline according to ANSI B92.1a, 30° pressure angle, flat root, side fit, tolerance class 5

2) Thread according to ASME B1.1

3) Depending on the application, momentary pressure peaks can occur. Keep this in mind when selecting measuring devices and fittings.

4) Only dimensions according to SAE J518, metric fastening thread is a deviation from the standard.

5) The countersink can be deeper than the standard. Ports designed for straight stud ends according to EN ISO 6149-2 or ISO 11926-2

6) Depending on installation position, T₁ or T₂ must be connected (see also installation instructions on page 30)

7) Optional, see page 25

8) Depending on function execution, the port size can vary

9) O = Must be connected (plugged on delivery)

X = Plugged (normal operation)

Dimensions, size 125–125

EP – Proportional control, electric

SAE working ports A and B, same side left (viewed on drive shaft)¹⁾

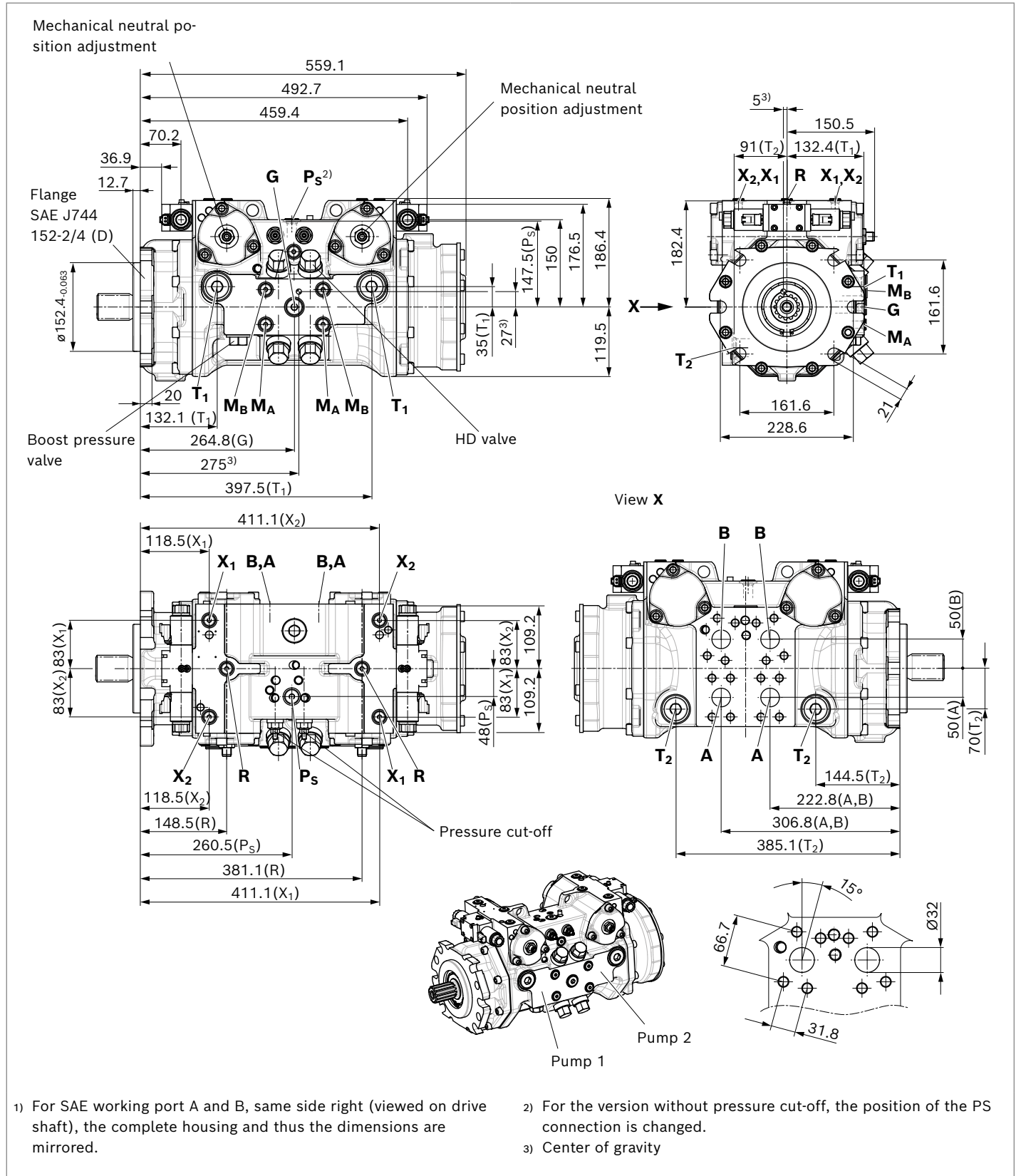

▼ Splined shaft ANSI B92.1a

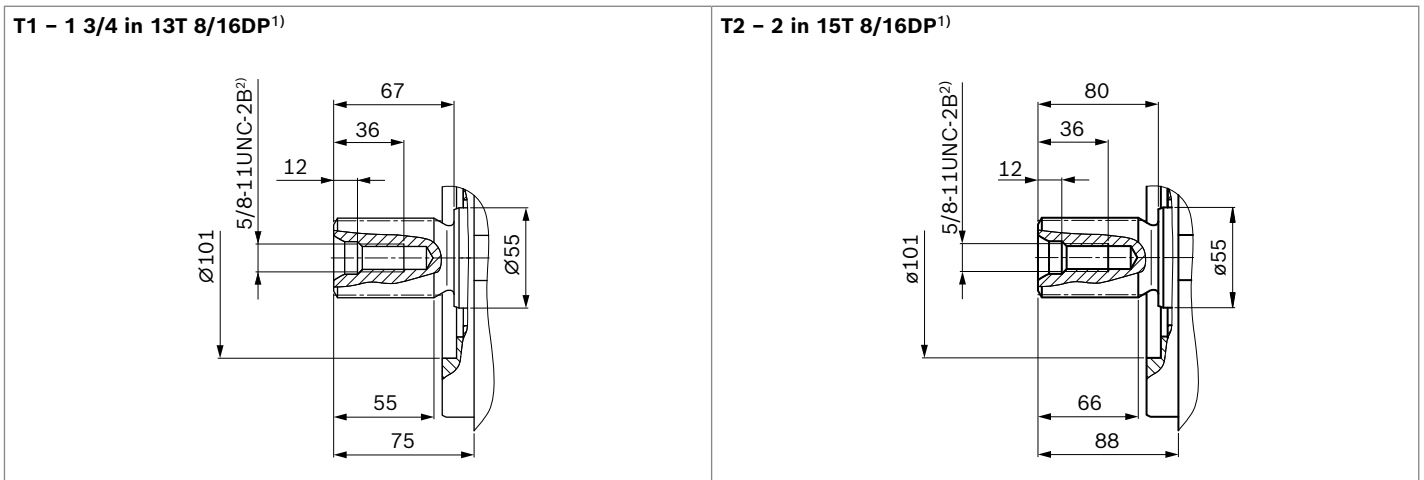

| Ports version "M", metric | | Standard | Size | p_{\max} [bar] ³⁾ | State ⁹⁾ | |
|--|---|---------------------------------|----------------------------------|-----------------------------------|---------------------|-----------------|
| | | | | | Pump 1 | Pump 2 |
| A, B | Working port Fastening thread | SAEJ518 ⁴⁾ DIN 13 | 1 1/4 in M14 × 2; 19 deep | 500 | O | O |
| T₁ | Drain port | ISO 6149 ⁵⁾ | M27 × 2; 19 deep | 3 | X ⁶⁾ | X ⁶⁾ |
| T₂ | Drain port | ISO 6149 ⁵⁾ | M27 × 2; 19 deep | 3 | X ⁶⁾ | O ⁶⁾ |
| R | Air bleed port | ISO 6149 ⁵⁾ | M14 × 1.5; 11.5 deep | 3 | X | X |
| X₁, X₂ | Control pressure port (upstream of orifice) | ISO 6149 ⁵⁾ | M14 × 1.5; 11.5 deep | 40 | X | X |
| X₃, X₄⁷⁾ | Stroking chamber pressure port | ISO 6149 ⁵⁾ | M14 × 1.5; 11.5 deep | 40 | X | X |
| G | Boost pressure port inlet | ISO 6149 ⁵⁾ | M22 × 1.5; 17 deep | 40 | | O |
| P_S | Pilot pressure port inlet | ISO 6149 ⁵⁾ | M18×1.5; 14.5 deep ⁸⁾ | 40 | | X |
| M_A, M_B | Measuring port pressure A, B | ISO 6149 ⁵⁾ | M14 × 1.5; 11.5 deep | 500 | X | X |

| Ports version "D", ANSI, metric fastening thread | | Standard | Size | p_{\max} [bar] ³⁾ | State ⁹⁾ | |
|--|---|---------------------------------|--|-----------------------------------|---------------------|-----------------|
| | | | | | Pump 1 | Pump 2 |
| A, B | Working port Fastening thread | SAEJ518 ⁴⁾ DIN 13 | 1 1/4 in M14 × 2; 19 deep | 500 | O | O |
| T₁ | Drain port | ISO 11926 ⁵⁾ | 1 1/16 -12 UN-2B; 20 deep | 3 | X ⁶⁾ | X ⁶⁾ |
| T₂ | Drain port | ISO 11926 ⁵⁾ | 1 1/16 -12 UN-2B; 20 deep | 3 | X ⁶⁾ | O ⁶⁾ |
| R | Air bleed port | ISO 11926 ⁵⁾ | 9/16 -18 UNF-2B; 13 deep | 3 | X | X |
| X₁, X₂ | Control pressure port (upstream of orifice) | ISO 11926 ⁵⁾ | 9/16 -18 UNF-2B; 13 deep | 40 | X | X |
| X₃, X₄⁷⁾ | Stroking chamber pressure port | ISO 11926 ⁵⁾ | 9/16 -18 UNF-2B; 13 deep | 40 | X | X |
| G | Boost pressure port inlet | ISO 11926 ⁵⁾ | 7/8 -14 UNF-2B; 17 deep | 40 | | O |
| P_S | Pilot pressure port inlet | ISO 11926 ⁵⁾ | 9/16 -18 UNF-2B; 13 deep ⁸⁾ | 40 | | X |
| M_A, M_B | Measuring port pressure A, B | ISO 11926 ⁵⁾ | 9/16 -18 UNF-2B; 13 deep | 500 | X | X |

- 1) Involute spline according to ANSI B92.1a, 30° pressure angle, flat root, side fit, tolerance class 5
- 2) Thread according to ASME B1.1
- 3) Depending on the application, momentary pressure peaks can occur. Keep this in mind when selecting measuring devices and fittings.
- 4) Only dimensions according to SAE J518, metric fastening thread is a deviation from the standard.

- 5) The countersink can be deeper than the standard. Ports designed for straight stud ends according to EN ISO 6149-2 or ISO 11926-2
- 6) Depending on installation position, T₁ or T₂ must be connected (see also installation instructions on page 30)
- 7) Optional, see page 25
- 8) Depending on function execution, the port size can vary
- 9) O = Must be connected (plugged on delivery)
X = Plugged (normal operation)

Dimensions, through drive

| Flange SAE J744 ¹⁾ | | | Hub for splined shaft ²⁾ | | | | | | |
|-------------------------------|------------------------|------|-------------------------------------|------|---------------|-----|-----|-----|------|
| Diameter | Mounting ³⁾ | Code | Diameter | Code | NG for pump 2 | 085 | 110 | 125 | Code |
| Without through drive | | | | | | ● | ● | ● | 0000 |

▼ Without through drive

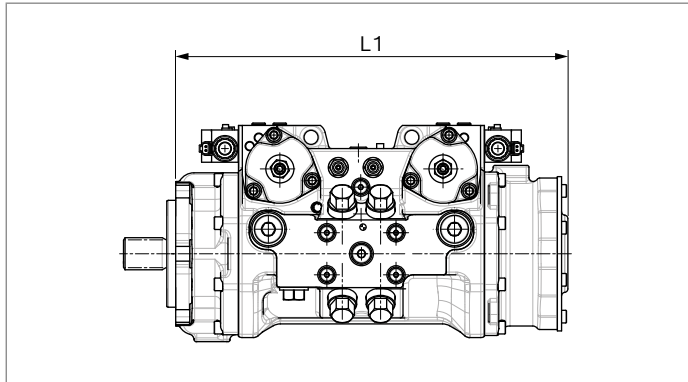

| NG | Mounting flange | | L1 |
|----------------|-----------------|-----------|-------|
| 85-85 | 152-2/4 | D6 | 559.1 |
| 110-85 | 152-2/4 | D6 | 559.1 |
| 110-110 | 152-2/4 | D6 | 559.1 |
| 125-85 | 152-2/4 | D6 | 559.1 |
| 125-110 | 152-2/4 | D6 | 559.1 |
| 125-125 | 152-2/4 | D6 | 559.1 |
| 85-85 | 165-4 | E4 | 559.1 |
| 110-110 | 165-4 | E4 | 559.1 |
| 125-125 | 165-4 | E4 | 559.1 |

- 1) The through-drive flange is only supplied with a metric fastening thread.
- 2) Involute spline according to ANSI B92.1a, 30° pressure angle, flat root, side fit, tolerance class 5
- 3) Mounting holes pattern viewed on through drive with control at top

| Flange SAE J744 ¹⁾ | | | Hub for splined shaft ²⁾ | | | Availability | | | |
|-------------------------------|------------------------|------|-------------------------------------|-------------|------|--------------|-----|-----|-------------|
| Diameter | Mounting ³⁾ | Code | Diameter | | Code | 085 | 110 | 125 | Code |
| 101-2 (B) | ⌀ | B1 | 7/8 in | 13T 16/32DP | S4 | - | - | ○ | B1S4 |
| | | | 1 in | 15T 16/32DP | S5 | - | - | ○ | B1S5 |
| | ∞ | B2 | 7/8 in | 13T 16/32DP | S4 | - | - | ● | B2S4 |
| | | | 1 in | 15T 16/32DP | S5 | - | - | ● | B2S5 |

▼ **101-2**

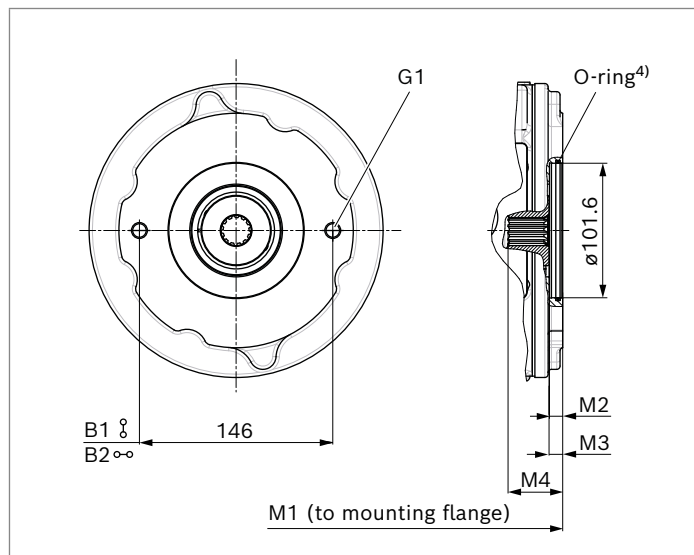

| NG | M1 | M2 ⁵⁾ | M3 | M4 | G1 ⁶⁾ |
|----------------|-------|------------------|------|------|-------------------|
| 125-125 | 541.6 | min. 8.8 | 10.5 | 43.5 | M12×1.75; 16 deep |

1) The through-drive flange is only supplied with a metric fastening thread.
 2) Involute spline according to ANSI B92.1a, 30° pressure angle, flat root, side fit, tolerance class 5
 3) Mounting holes pattern viewed on through drive with control at top

4) O-ring included in the scope of delivery
 5) According to SAE J744
 6) Thread according to DIN 13

| Flange SAE J744 ¹⁾ | | | Hub for splined shaft ²⁾ | | | Availability | | | |
|-------------------------------|------------------------|------|-------------------------------------|-------------|------|--------------|-----|-----|------|
| Diameter | Mounting ³⁾ | Code | Diameter | | Code | 085 | 110 | 125 | Code |
| 127-2 (C) | ⌀ | C1 | 1 3/8 in | 21T 16/32DP | V8 | ● | ● | ● | C1V8 |
| | ∞ | C2 | 1 1/4 in | 14T 12/24DP | S7 | ● | ● | ● | C2S7 |
| 127-4 (C) | ⌀ | C4 | 1 1/4 in | 14T 12/24DP | S7 | ● | ● | ● | C4S7 |
| | ∞ | | 1 3/8 in | 21T 16/32DP | V8 | ● | ● | ● | C4V8 |

▼ **127-2, 127-4**

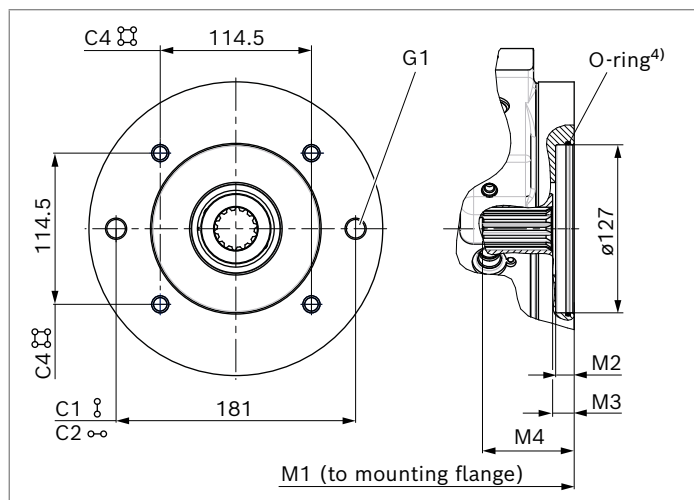

| NG | M1 | M2 ⁵⁾ | M3 | M4 | G1 ⁶⁾ | |
|---------|-------|------------------|----|----|------------------|-------------|
| | | | | | 2-hole | 4-hole |
| 85-85 | 544.1 | min. 8.8 | 13 | 58 | | |
| 110-85 | 544.1 | min. 8.8 | 13 | 58 | | |
| 110-110 | 544.1 | min. 8.8 | 13 | 58 | M16 × 2; | M12 × 1.75; |
| 125-85 | 544.1 | min. 8.8 | 13 | 58 | 21 deep | 19 deep |
| 125-110 | 544.1 | min. 8.8 | 13 | 58 | | |
| 125-125 | 544.1 | min. 8.8 | 13 | 58 | | |

1) The through-drive flange is only supplied with a metric fastening thread.
 2) Involute spline according to ANSI B92.1a, 30° pressure angle, flat root, side fit, tolerance class 5
 3) Mounting holes pattern viewed on through drive with control at top

4) O-ring included in the scope of delivery
 5) According to SAE J744
 6) Thread according to DIN 13

Overview of mounting options

| Through drive ¹⁾ | | Mounting option – additional pump | | | | | | | | | |
|-----------------------------|-----------------------|-----------------------------------|-----------------------|-----------------------|-----------------------|------------------------|------------------------|-------------------------------|------------------------|-----------------------|---|
| Flange | Hub for splined shaft | Code | A4VG/40 NG (shaft) | A4VG/35 NG (shaft) | A4VG/32 NG (shaft) | A10VG/10 NG (shaft) | A10VO/3X NG (shaft) | A10VO/5X NG (shaft) | A11VO/1X NG (shaft) | A1VO/10 NG (shaft) | External gear pump ²⁾ |
| 101-2 (B) | 7/8 in | B_S4 | – | – | – | 18 (S) | 28 (S) 45 (U) | 28 (S) 45 (U) | – | 35 (S4) | AZPN–11 NG20 ... 25 AZPG–22 NG28 ... 100 |
| 101-2 (B) | 1 in | B_S5 | – | – | 28 (S) | 28, 45 (S) | 45 (S) | 45 (S), 60, 63, 72 (U) | 40 (S) | – | – |
| 127-2 (C) | 1 1/4 in | C_S7 | – | 56 (S7) | 40, 56, 71 (S) | 63 (S) | 71 (S) 100 (U) | 85, 100 (U) | 60 (S) | – | – |
| | 1 3/8 in | C_V8 | 110 (V8) | – | 56, 71 (T) | 63 (T) | – | – | 60 (T) | – | – |
| 127-4 (C) | 1 1/4 in | C4S7 | – | 71 (S7) | 71 (S) | – | – | 60, 63, 72 (S) 85, 100 (U) | – | – | – |
| | 1 3/8 in | C4V8 | 110 (V8) | 90 (T1) | 71 (T) | – | – | – | – | – | – |

Notice

The mounting options listed only apply for drive shaft versions with undercut. Please contact us for drive shafts without undercut.

1) Availability of the individual sizes, see type code.

2) Bosch Rexroth recommends special versions of the gear pumps. Please contact us.

High-pressure relief valves

The four high-pressure relief valves protect the hydrostatic gear (pump and motor) from overloading. They limit the maximum pressure in the respective high-pressure line and serve simultaneously as boost valves.

High-pressure relief valves are not working valves and are only suitable for pressure peaks or high rates of pressure change.

Setting ranges

| High-pressure relief valve, direct operated | Differential pressure setting Δp_{HD} [bar] |
|---|---|
| Preferred values | 400, 410, 420, 430, 440, 450, 460, 470 |
| Optional values | 300, 320, 340, 360, 380 |

Settings on high-pressure relief valve A and B (Pump 1 and 2)

| | |
|--|-----------------------------|
| Differential pressure setting | $\Delta p_{HD} = \dots$ bar |
| Cracking pressure of the HD valve (at q_{V1}): ($p_{max} = \Delta p_{HD} + p_{Sp}$) | $p_{max} = \dots$ bar |

- ▶ The valve settings are made at $n = 1000$ rpm and at $V_{g\ max}$ (q_{V1}). There may be deviations in the cracking pressures with other operating parameters.
- ▶ When ordering, state the differential pressure setting Δp_{HD} in the plain text.

Setting diagram

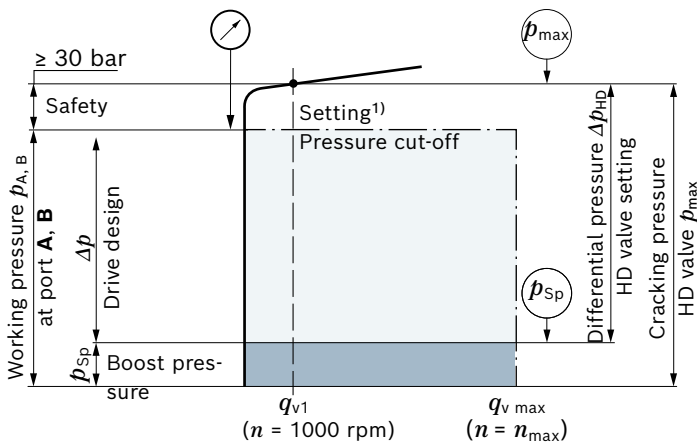

Example: Δp drive design = 430 bar ($p_{A,B} - p_{Sp}$)

| Working pressure $p_{A,B}$ | - | Boost pressure p_{Sp} | + | Safety | = | Differential pressure Δp_{HD} |
|----------------------------|---|-------------------------|---|--------|---|---------------------------------------|
| 450 bar | - | 20 bar | + | 30 bar | = | 460 bar |

- ▶ Cracking pressure of the HD valve (at q_{V1}): $p_{max} = 480$ bar ($p_{max} = \Delta p_{HD} + p_{Sp}$)

▼ Circuit diagram

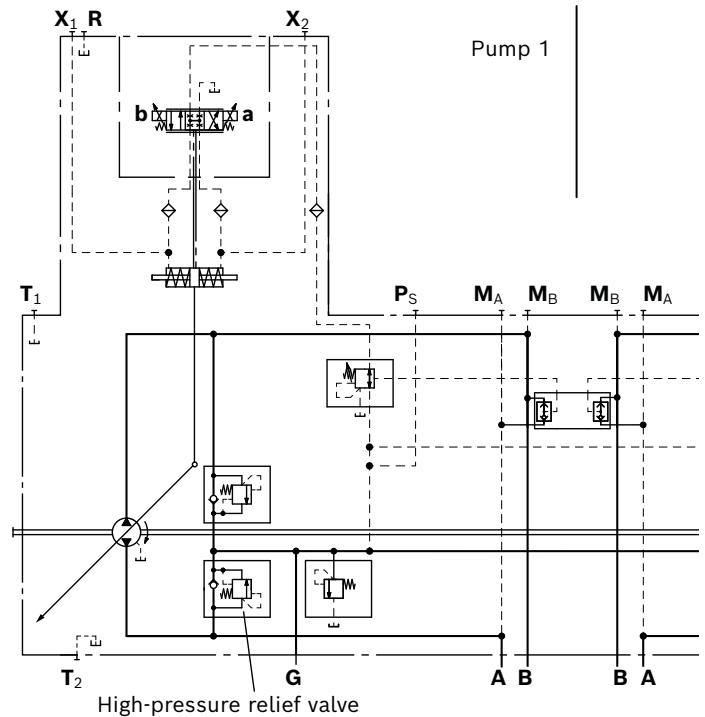

Key

| | |
|--|---|
| HD valve | High-pressure relief valve |
| Cracking pressure HD valve p_{max} | When the set pressure value is reached, the HD valve opens and thus protects the hydrostatic gear (pump and motor) from overloading |
| Differential pressure HD valve Δp_{HD} | Cracking pressure HD valve (abs.) minus the boost pressure setting |
| Working pressure $p_{A,B}$ | The total design of the customer machine is based on this pressure value. It comprises the boost pressure setting and the Δp drive design. |
| Δp drive design | Differential pressure value determining the available torque at the hydraulic motor ($p_{A,B} - p_{Sp}$). |
| Boost pressure p_{Sp} | Boost pressure setting of the low-pressure valve |
| Safety | Required distance between working pressure (and/or pressure cut-off) and cracking pressure of the high-pressure relief valve to ensure the intended function of the high-pressure relief valve. |

Notice

Upon response of the high-pressure relief valve, the permissible temperature and viscosity must be complied with.

1) Omitted with version without pressure cut-off

Pressure cut-off

The pressure cut-off corresponds to a pressure control which, after reaching the set pressure, adjusts the displacement of the pump back to $V_{g\ min}$. This valve prevents the operation of the high-pressure relief valves when accelerating or decelerating. The high-pressure relief valves protect against the pressure peaks which occur during fast swiveling of the swashplate and limit the maximum pressure in the system.

The setting range of the pressure cut-off may be anywhere within the entire working pressure range. However, it must be set 30 bar lower than the setting value of the high-pressure relief valves (see setting diagram, page 22). Please state the setting value of the pressure cut-off in plain text when ordering.

▼ Circuit diagram with pressure cut-off

Example: Electric control, EP_R

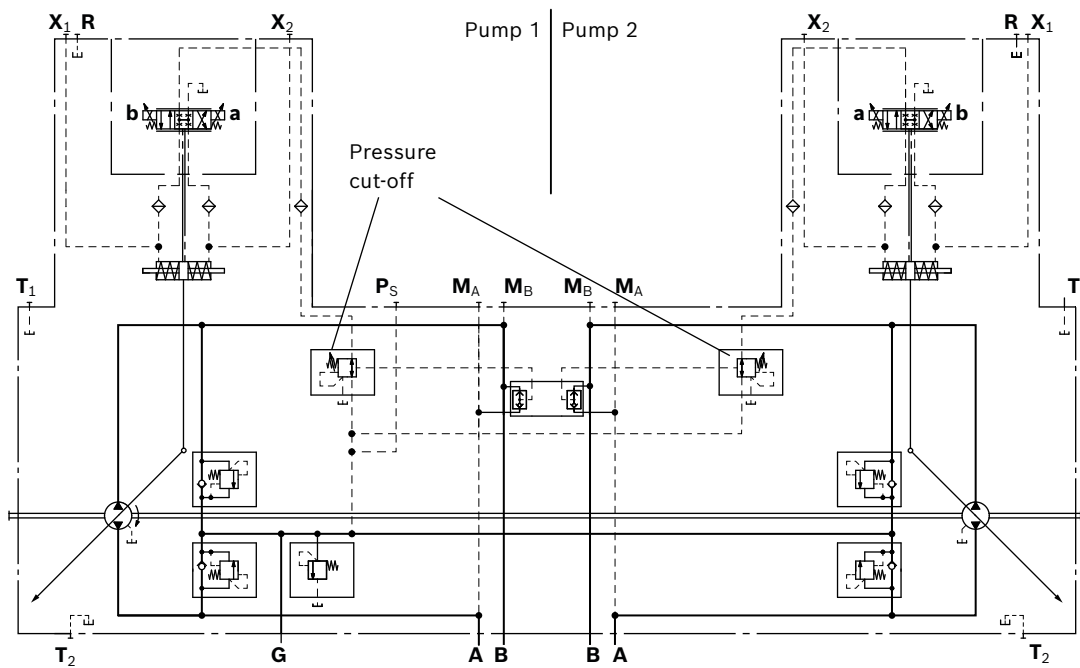

Mechanical stroke limiter

The mechanical stroke limiter is an auxiliary function allowing the maximum displacement of the pump to be continuously reduced, regardless of the control module used.

Two threaded pins per pump are used to adjust the stroke of the stroking piston and thus limit the maximum swivel angle of each pump.

Dimensions

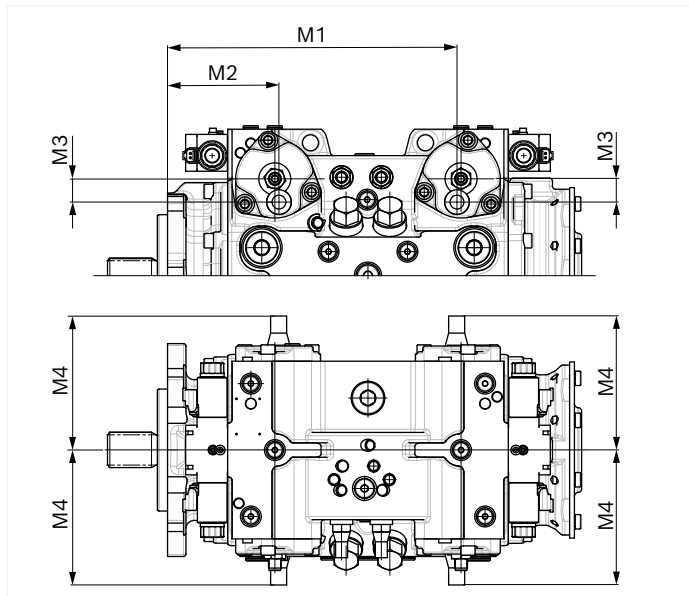

| NG | M1 | M2 | M3 | M4 |
|---------|-----|-------|------|----------|
| 85-85 | 376 | 153.6 | 29.1 | max. 162 |
| 110-85 | 376 | 153.6 | 29.1 | max. 162 |
| 110-110 | 376 | 153.6 | 29.1 | max. 162 |
| 125-85 | 376 | 153.6 | 29.1 | max. 162 |
| 125-110 | 376 | 153.6 | 29.1 | max. 162 |
| 125-125 | 376 | 153.6 | 29.1 | max. 162 |

Notice

Threaded pins are mounted from the inside (screw-out protection) and can no longer be removed from the outside.

▼ Circuit diagram

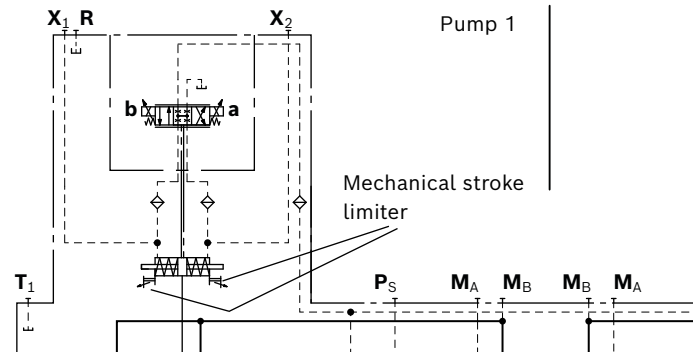

Stroking chamber pressure port X3 and X4

Dimensions

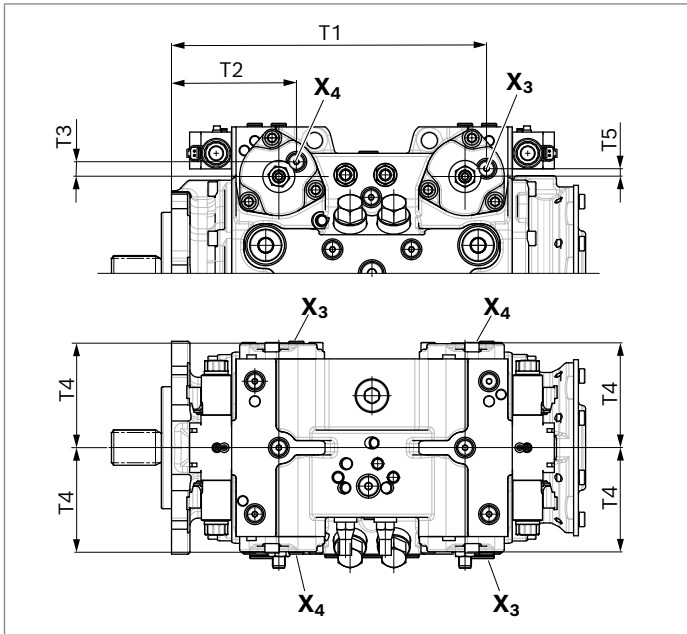

▼ Circuit diagram

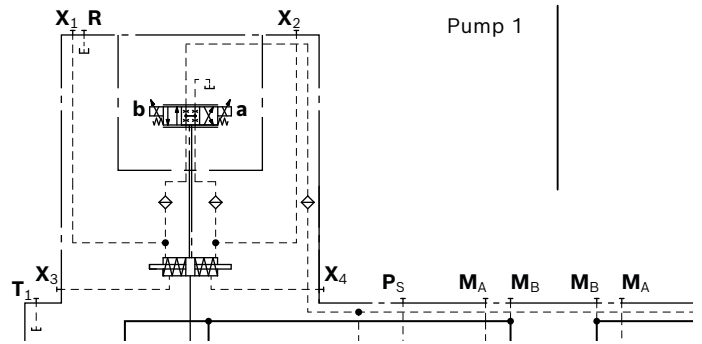

| NG | T1 | T2 | T3 | T4 | T5 |
|---------|-------|-------|------|-----|-----|
| 85-85 | 407.9 | 170.3 | 18.3 | 128 | 9.7 |
| 110-85 | 407.9 | 170.3 | 18.3 | 128 | 9.7 |
| 110-110 | 407.9 | 170.3 | 18.3 | 128 | 9.7 |
| 125-85 | 407.9 | 170.3 | 18.3 | 128 | 9.7 |
| 125-110 | 407.9 | 170.3 | 18.3 | 128 | 9.7 |
| 125-125 | 407.9 | 170.3 | 18.3 | 128 | 9.7 |

| Ports | Standard ¹⁾ | Size | p_{max} [bar] ²⁾ | State ³⁾ | |
|---------------------------------|------------------------|----------------------|-------------------------------|---------------------|--------|
| | | | | Pump 1 | Pump 2 |
| X ₃ , X ₄ | ISO 6149 | M14 × 1.5; 11.5 deep | 40 | X | X |

| Ports | Standard ¹⁾ | Size | p_{max} [bar] ²⁾ | State ³⁾ | |
|---------------------------------|------------------------|--------------------------|-------------------------------|---------------------|--------|
| | | | | Pump 1 | Pump 2 |
| X ₃ , X ₄ | ISO 11926 | 9/16 -18 UNF-2B; 13 deep | 40 | X | X |

1) The countersink can be deeper than the standard. Ports designed for straight stud ends according to EN ISO 6149-2 or ISO 11926-2.

2) Depending on the application, momentary pressure peaks can occur. Keep this in mind when selecting measuring devices and fittings.

3) X = Plugged (in normal operation)

Filtration boost circuit / external boost pressure supply

Version external boost pressure supply

The boost pressure supply comes from port **G**.

The filter should be installed separately on port **G** before the boost pressure supply.

To ensure functional reliability, maintain the required cleanliness level for the boost pressure fluid fed in at port **G** (see page 6).

▼ Circuit diagram

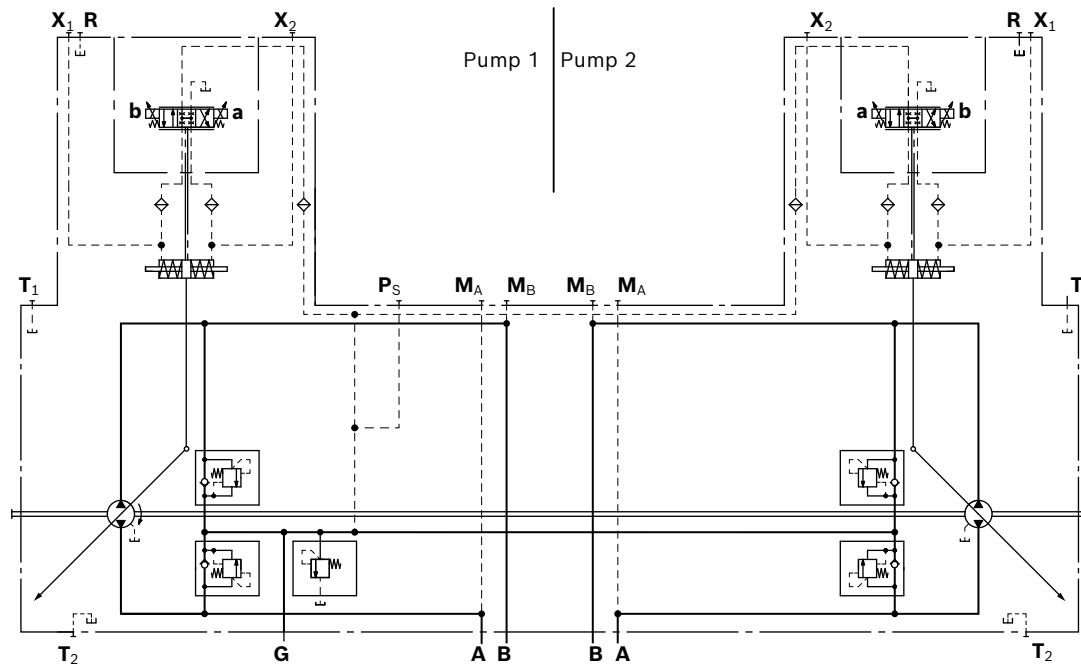

Connector for solenoids

DEUTSCH DT04-2P-EP04

- ▶ Molded, 2-pin, without bidirectional suppressor diode (standard).

The installed mating connector has the following

Type of protection:

- ▶ IP67 (DIN/EN 60529) and
- ▶ IP69K (DIN 40050-9)

▼ Switching symbol

without bidirectional suppressor diode

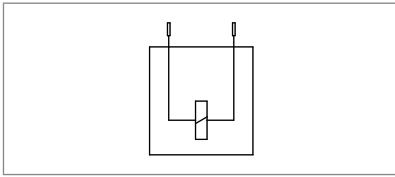

▼ Mating connector DEUTSCH DT06-2S-EP04

| Consisting of | DT designation |
|---------------|----------------|
| 1 housing | DT06-2S-EP04 |
| 1 wedge | W2S |
| 2 sockets | 0462-201-16141 |

The mating connector is not included in the scope of delivery. This can be supplied by Bosch Rexroth on request (material number R902601804).

Notice

- ▶ If necessary, you can change the position of the connector by turning the solenoid body.
- ▶ The procedure is defined in the instruction manual.

Pressure Sensor

The pressure on the working ports **A** and **B** can be recorded using the mounted PR4 pressure sensors (version M; 0 to 600 bar) in **M_A** and **M_B**. Type code, technical data, dimensions and details on the connector, plus safety instructions about the sensor can be found in the relevant data sheet 95156.

Notice

Due to the working pressure range of the A24VG series 10 from a nominal pressure of 450 bar and maximum pressure of 500 bar, only version M of the PR4 pressure sensor is approved.

Swivel angle sensor

The swivel angle sensor is used to detect the swivel angle of axial piston units and thus the displacement using a Hall-effect based sensor IC. The determined measurement value is converted into an analog signal.

Please contact us if the swivel angle sensor is used for control.

| Characteristics | |
|--|--|
| Supply voltage U_b | 10 to 30 V DC |
| Output voltage U_a | 1 V 2.5 V 4 V ($V_{g \max}$) ($V_{g 0}$) ($V_{g \max}$) |
| Reverse polarity protection | Short circuit resistant |
| EMC resistance | Details on request |
| Operating temperature range | -40 °C to +115 °C |
| Vibration resistance sinusoidal vibration EN 60068-2-6 | 10 g / 5 to 2000 Hz |
| Shock resistance continuous shock IEC 68-2-29 | 25 g |
| Salt spray resistance DIN 50021-SS | 96 h |
| Type of protection with installed mating connector | IP67 – DIN EN 60529 IP69K – DIN 40050-9 |
| Housing material | Plastic |
| Connector version | DEUTSCH DT04-3P |

Output voltage

| Direction of rotation | Flow direction ¹⁾ | Working pressure | Output voltage |
|-----------------------|------------------------------|------------------|----------------|
| clockwise | B to A | M_A | > 2.5 V |
| | A to B | M_B | < 2.5 V |
| counter-clockwise | A to B | M_B | > 2.5 V |
| | B to A | M_A | < 2.5 V |

1) For flow direction, see controls

▼ Circuit diagram

Illustration with working ports located on left

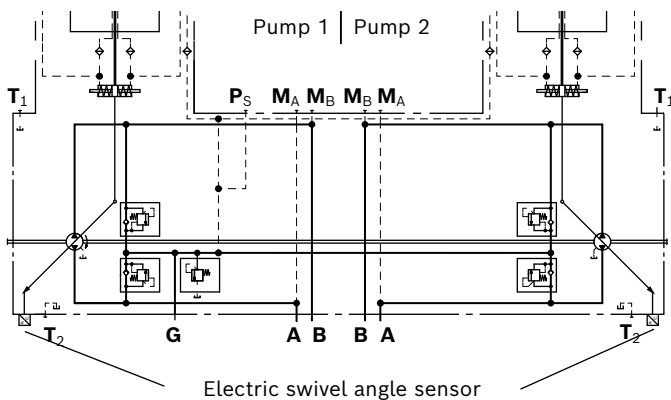

Dimensions

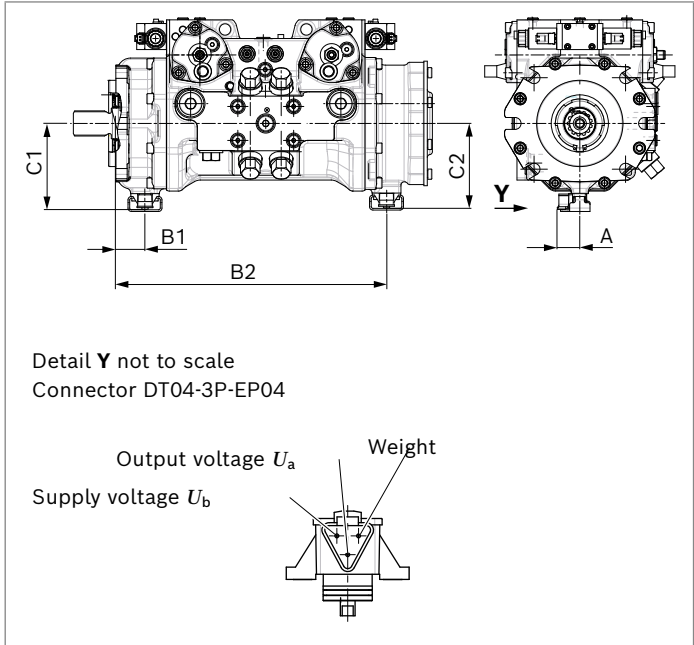

| NG | A | B1 | B2 | C1 | C2 |
|----------------|----|------|-------|-------|-------|
| 85-85 | 37 | 51.5 | 478.1 | 150.5 | 150.5 |
| 110-85 | 37 | 51.5 | 478.1 | 150.5 | 150.5 |
| 110-110 | 37 | 51.5 | 478.1 | 150.5 | 150.5 |
| 125-85 | 37 | 51.5 | 478.1 | 150.5 | 150.5 |
| 125-110 | 37 | 51.5 | 478.1 | 150.5 | 150.5 |
| 125-125 | 37 | 51.5 | 478.1 | 150.5 | 150.5 |

Mating connector DEUTSCH DT06-3S-EP04

| Consisting of | DT designation |
|---------------|----------------|
| 1 housing | DT06-3S-EP04 |
| 1 wedge | W3S |
| 3 sockets | 0462-201-16141 |

The mating connector is not included in the scope of delivery. This can be supplied by Bosch Rexroth on request (material number R902603524).

Notice

- ▶ It is not possible to retrofit existing units with a swivel angle sensor.
 - ▶ Available with E4 flange and in combination without through drive.
- For other versions, please contact us.

Installation dimensions for coupling assembly

To ensure that rotating components (coupling hub on drive shaft) and fixed components (housing, retaining ring) do not come into contact with each other, the installation conditions described here must be observed. This depends on the pump size and the splined shaft.

SAE splined shaft (spline according to ANSI B92.1a)

The outer diameter of the coupling hub must be smaller than the inner diameter of the retaining ring (dimension d_2) in the area near the drive shaft collar (dimension $X_2 - X_3$).

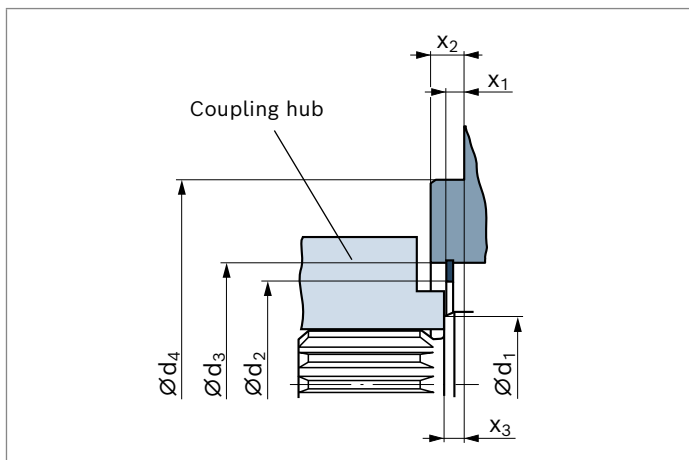

| NG | Mounting flange | $\text{Ø}d_1$ | $\text{Ø}d_{2 \text{ min}}$ | $\text{Ø}d_3$ | $\text{Ø}d_4$ | X_1 | X_2 | X_3 |
|------------|-----------------|---------------|-----------------------------|---------------|---------------------------------------|-------|----------------------|-----------------------------------|
| 85 | 152-2/4 (D) | 53.4 | 74.4 | 101±0.1 | 152.4 ⁺⁰ _{-0.063} | 6.0 | 12.7 _{-0.5} | 8 ^{+0.9} _{-0.6} |
| | 165-4 (E) | 53.4 | 74.4 | 101±0.1 | 165.1 ⁺⁰ _{-0.063} | 6.0 | 15.9 _{-0.5} | 8 ^{+0.9} _{-0.6} |
| 110 | 152-2/4 (D) | 53.4 | 74.4 | 101±0.1 | 152.4 ⁺⁰ _{-0.063} | 6.0 | 12.7 _{-0.5} | 8 ^{+0.9} _{-0.6} |
| | 165-4 (E) | 53.4 | 74.4 | 101±0.1 | 165.1 ⁺⁰ _{-0.063} | 6.0 | 15.9 _{-0.5} | 8 ^{+0.9} _{-0.6} |
| 125 | 152-2/4 (D) | 53.4 | 74.4 | 101±0.1 | 152.4 ⁺⁰ _{-0.063} | 6.0 | 12.7 _{-0.5} | 8 ^{+0.9} _{-0.6} |
| | 165-4 (E) | 53.4 | 74.4 | 101±0.1 | 165.1 ⁺⁰ _{-0.063} | 6.0 | 15.9 _{-0.5} | 8 ^{+0.9} _{-0.6} |

Installation instructions

General

The axial piston unit must be filled with hydraulic fluid and air bled during commissioning and operation. This must also be observed following a longer standstill as the axial piston unit may empty via the hydraulic lines.

The leakage in the housing area must be directed to the reservoir via the highest drain port (**T₁**, **T₂**).

For combination pumps, the leakage must be drained off at each single pump.

If a shared drain line is used for several units, make sure that the respective case pressure in each unit is not exceeded. The shared drain line must be dimensioned to ensure that the maximum permissible case pressure of all connected units is not exceeded in any operating condition, particularly at cold start. If this is not possible, separate drain line must be laid, if necessary.

To achieve favorable noise values, decouple all connecting lines using elastic elements and avoid above-reservoir installation.

In all operating conditions, the drain line must flow into the reservoir below the minimum fluid level.

Drain line port

Besides the actual case drain fluid, an additional cooling fluid flow is required in the housing for lubricating and cooling the rotary group in the housing. To guarantee the flushing of both rotary groups, the connection specifications for the **T**-ports must be observed.

- ▶ **Internal flushing:** If the integrated boost pressure valve is used, internal flushing is guaranteed.
- ▶ **External flushing:** If the boost pressure is backed up with an external pressure relief valve, external flushing of the pump housing via the **T**-ports will be required.

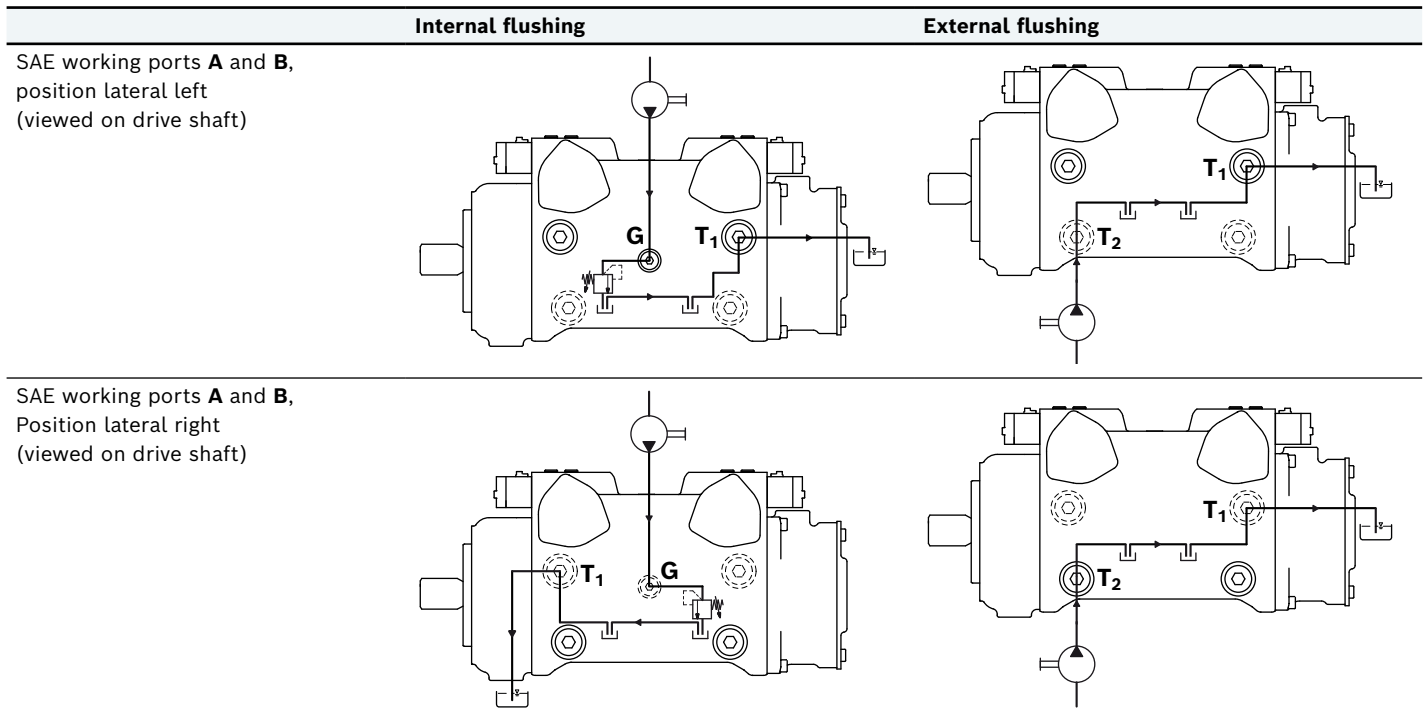

Installation position

See the following examples **1** to **8**.
Further installation positions are available upon request.
Recommended installation position: **1**.

Notice

- ▶ If filling the stroking chambers via **X₁** to **X₄** in the final installation position is not possible, then this must be carried out before installation.
- ▶ To prevent unexpected actuation and damage, the stroking chambers must be air bled via the ports **X₁**, **X₂** or **X₃**, **X₄** depending on the installation position.
- ▶ In certain installation positions, an influence on the adjustment or control can be expected. Gravity, dead weight and case pressure can cause minor characteristic shifts and changes in response time.

| Key | |
|-------------------------------------|--|
| F₁ | Filling / Air bleeding |
| R | Air bleed port |
| T₁, T₂ | Drain port |
| X₁, X₂ | Control pressure port |
| X₃, X₄ | Stroking chamber pressure port |
| $h_{t\ min}$ | Minimum required immersion depth (200 mm) |
| h_{min} | Minimum required distance to reservoir bottom (100 mm) |

Below-reservoir installation (standard)

Below-reservoir installation means that the axial piston unit is installed outside of the reservoir below the minimum fluid level.

| Installation position | Air bleeding the housing | Air bleeding the stroking chamber | Filling |
|-----------------------|--------------------------|-------------------------------------|--|
| 1 | R | X₁, X₂ | T₁ + X₁ + X₂ |
| | | | |
| 2 | - | - | T₂ |
| | | | |
| 3 | - | X₃, X₄ | T₂ + X₃ + X₄ |
| | | | |
| 4 | - | X₃, X₄ | T₁ + X₃ + X₄ |
| | | | |

Above-reservoir installation

Above-reservoir installation means that the axial piston unit is installed above the minimum fluid level of the reservoir.

Notice

Port **F₁** is part of the external piping and must be provided on the customer side to make filling and air bleeding easier.

| Installation position | Air bleeding the housing | Air bleeding the stroking chamber | Filling |
|-----------------------|--------------------------|-----------------------------------|--|
| 5 | R | X ₁ , X ₂ | F ₁ + X ₁ + X ₂ |

For key and notes, see page 31.

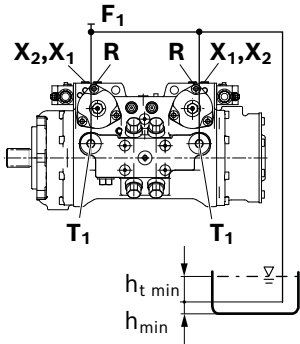

| | | | |
|---|----------------------------------|---|----------------------------------|
| 6 | F ₁ (T ₂) | - | F ₁ (T ₂) |
|---|----------------------------------|---|----------------------------------|

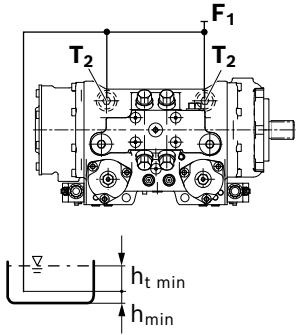

| | | | |
|---|----------------------------------|---------------------------------|--|
| 7 | F ₁ (T ₂) | X ₃ , X ₄ | F ₁ (T ₂) + X ₃ + X ₄ |
|---|----------------------------------|---------------------------------|--|

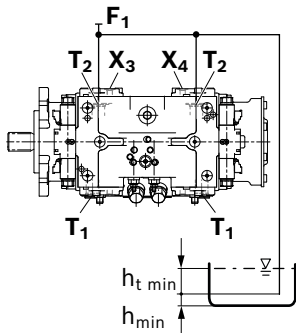

| | | | |
|---|----------------------------------|---|--|
| 8 | F ₁ (T ₁) | - | F ₁ (T ₁) + X ₃ + X ₄ |
|---|----------------------------------|---|--|

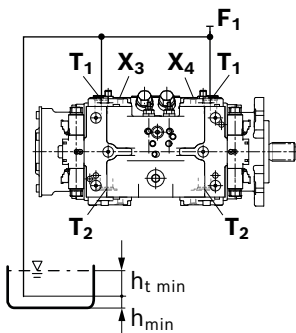

Project planning notes

- ▶ The pump is intended for use in a closed circuit.
- ▶ Project planning, installation and commissioning of the axial piston units requires the involvement of skilled personnel.
- ▶ Before using the axial piston unit, please read the appropriate instruction manual thoroughly and in full. If necessary, this can be requested from Bosch Rexroth.
- ▶ Before finalizing your design, request a binding installation drawing.
- ▶ The specified data and notes contained herein must be observed.
- ▶ Depending on the operating conditions of the axial piston unit (working pressure, fluid temperature), the characteristic curve may shift.
- ▶ Preservation: Our axial piston units are supplied as standard with preservative protection for a maximum of 12 months. If longer preservative protection is required (maximum 24 months), please specify this in plain text when placing your order. The preservation periods apply under optimal storage conditions, details of which can be found in the data sheet 90312 or the instruction manual.
- ▶ Not all versions of the product are approved for use in safety functions according to ISO 13849. Please consult the responsible contact person at Bosch Rexroth if you require reliability parameters (e.g. $MTTF_D$) for functional safety.
- ▶ Depending on the type of control used, electromagnetic effects can be produced when using solenoids. Applying a direct voltage signal (DC) to solenoids does not create electromagnetic interference (EMI) nor is the solenoid affected by EMI. Electromagnetic interference (EMI) potential exists when operating and controlling a solenoid with a modulated direct voltage signal (e.g. PWM signal) Appropriate testing and measures should be taken by the machine manufacturer to ensure other components or operators (e.g. with pacemaker) are not affected by this potential.
- ▶ The pressure cut-off is not a safeguard against pressure overload. Be sure to add a pressure relief valve to the hydraulic system.
- ▶ For drives that are operated for a long period with constant rotational speed, the natural frequency of the hydraulic system can be stimulated by the stimulator frequency of the pump (rotational speed frequency $\times 9$). This can be prevented with suitably designed hydraulic lines.
- ▶ Please note the details regarding the tightening torques of port threads and other threaded joints in the instruction manual.
- ▶ Working ports:
 - The ports and fastening threads are designed for the specified maximum pressure. The machine or system manufacturer must ensure the connecting elements and lines correspond to the specified application conditions (pressure, flow, hydraulic fluid, temperature) with the necessary safety factors.
 - The service ports and function ports are only intended to accommodate hydraulic lines.
- ▶ With dynamic power flow (switch of pumps to operation as a motor) a maximum of 95% $V_{g \max}$ is permissible. We recommend configuring the software accordingly.