

Axial piston variable pump A4VSG Series 1x and 3x

RE 92100

Edition: 03.2018

Replaces: 05.2011

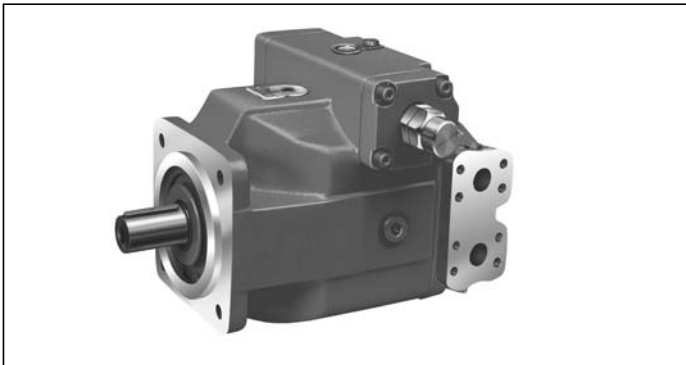

- ▶ Robust high-pressure pump for industrial applications
- ▶ Sizes 40 ... 1000
- ▶ Nominal pressure 350 bar
- ▶ Maximum pressure 400 bar
- ▶ Closed circuit

Features

- ▶ Robust pump with very long service life
- ▶ Reduced noise
- ▶ Through drive for mounting of further pumps up to same nominal size
- ▶ Flow direction changes smoothly when the swashplate is moved through the neutral position
- ▶ Axial and radial load capacity of the drive shaft
- ▶ Modular design
- ▶ Visual swivel angle indicator
- ▶ Short response times
- ▶ Operation on HF-fluids under reduced operational data possible
- ▶ Swashplate design

Contents

Type code	2
Hydraulic fluids	5
Working pressure range	7
Technical data	8
Overview of control device	10
Dimensions, size 40 to 1000	14
Dimensions, through drives	32
Overview of mounting options	44
Combination pumps A4VSG + A4VSG	45
Combination pumps A4VSG + A4VSO	45
Attachment of boost and control circuit pumps	
Order code: H02, H04 and H06	47
H024 – A4VSG with an attachment pump for the boost circuit, valve block with filter	48
Example: A4VSG 180....H024N	49
Installation instructions	50
Project planning notes	53
Safety instructions	54

Type code

01	02	03	04	05	06	07	08	09	10	11	12	13	14
	A4VS	G			/		-			10			

Hydraulic fluid		40	71	125	180	250	355	500	750	1000	
01	Mineral oil and HFD hydraulic fluids (no code)	•	•	•	•	•	•	•	•	•	
	HFA, HFB, and HFC hydraulic fluids	•	•	•	•	•	•	•	-	-	E

Axial piston unit		
02	Variable swashplate design, nominal pressure 350 bar, maximum pressure 400 bar	A4VS

Operating mode		
03	Pump, closed circuit	G

Size (NG)		40	71	125	180	250	355	500	750	1000
04	Geometric displacement, see table of values on page 8									

Control device		Data sheet	40	71	125	180	250	355	500	750	1000	
05	Manual control	92072	•	•	•	•	•	•	•	-	-	MA
	Electric motor control		•	•	•	•	•	•	•	-	-	EM
	Hydraulic control, control volume dependent	92076	•	•	•	•	•	•	•	•	•	HM..
	Hydraulic closed loop control with servo/proportional valve		•	•	•	•	•	•	•	•	•	HS..
	Hydraulic closed loop control, with proportional valve		•	•	•	•	•	•	•	•	•	EO..
	Hydraulic control, pilot-pressure related	92080	•	•	•	•	•	•	•	•	•	HD..
	Electrohydraulic control with proportional solenoid	92084	•	•	•	•	•	•	•	•	○	EP..
	Secondary closed loop rotational speed control	92058	•	•	•	•	•	•	•	•	•	DS2

Series		40	71	125	180	250	355	500	750	1000	
06	Series 1, index 0 (index 1)	•	•	-	-	-	-	-	-	-	10(11) ²⁾
	Series 3, index 0	-	-	•	•	▲	•	▲	•	•	30
	Series 3, index 3; efficiency-optimized rotary group	-	-	-	-	•	○	•	-	-	33

Direction of rotation		40 ... 1000	
07	Viewed on drive shaft	clockwise	R
		counter-clockwise	L
		variable	W ¹⁾

Sealing material		40 ... 1000
08	NBR (nitrile rubber), FKM shaft seal	P
	FKM (fluoroelastomer) / HFD operation	V

Drive shaft		40 ... 1000
09	Parallel keyed shaft DIN 6885	P
	Splined shaft DIN 5480	Z

Mounting flange		40	71	125	180	250	355	500	750	1000		
10	According to ISO 3019-2 metric	4-hole	•	•	•	•	•	•	-	-	-	B
		8-hole	-	-	-	-	-	-	•	•	•	H

Working port		40 ... 1000
11	SAE flange ports A and B , located laterally on same side, metric fastening thread	10











• = Available ○ = On request - = Not available ▲ = Not for new projects

1) Only in combination with DS2

2) Version with HD- and EP-controls in series 11

01	02	03	04	05	06	07	08	09	10	11	12	13	14
	A4VS	G			/			-			10		

Through drives (for mounting options, see page 44)

12	Flange ISO 3019-2 (metric) Hub for splined shaft	Diameter	Attachment ⁵⁾	Diameter	40	71	125	180	250	355	500	750	1000	
	Without through drive				●	●	●	●	●	●	●	●	●	N00
	125, 4-hole			32x22x14x9g ³⁾	●	●	●	●	●	○	○	○	○	K31
	140, 4-hole			40x2x18x9g ³⁾	-	●	●	●	●	●	●	○	●	K33
	160, -4-hole			50x2x24x9g ³⁾	-	-	●	●	●	●	●	○	○	K34
	224, 4-hole			60x2x28x9g ³⁾	-	-	-	-	●	●	●	●	●	K35
	224, 4-hole			70x3x22x9g ³⁾	-	-	-	-	-	●	●	○	○	K77
	315, 8-hole			80x3x25x9g ³⁾	-	-	-	-	-	-	●	○	○	K43
	400, 8-hole			90x3x28x9g ³⁾	-	-	-	-	-	-	-	●	●	K76
	400, 8-hole			100x3x32x9g ³⁾	-	-	-	-	-	-	-	-	●	K88
	80, 2-hole			3/4 in 11T 16/32DP ⁴⁾	○	●	●	○	○	○	○	○	○	KB2
	100, 2-hole			7/8 in 13T 16/32DP ⁴⁾	●	●	●	●	●	●	○	○	○	KB3
	100, 2-hole			1 in 15T 16/32DP ⁴⁾	○	●	●	●	●	○	○	○	○	KB4
	125, 2-hole			1 1/4 in 14T 12/24DP ⁴⁾	-	●	●	●	●	●	●	○	○	KB5
	160, 4-hole			1 1/4 in 14T 12/24DP ⁴⁾	○	○	○	○	○	○	○	○	○	KB8
	125, 2-hole			1 1/2 in 17T 12/24DP ⁴⁾	-	-	●	●	●	●	●	●	○	KB6
	180, 4-hole			1 1/2 in 17T 12/24DP ⁴⁾	-	-	○	○	○	○	○	○	○	KB9
	180, 4-hole			1 3/4 in 13T 8/16DP ⁴⁾	-	-	●	●	●	●	●	●	○	KB7
	Flange ISO 3019-1 (SAE) Hub for splined shaft													
	Through drive				40	71	125	180	250	355	500	750	1000	
	82-2 (A)			5/8 in 9T 16/32DP ⁴⁾	●	●	●	●	●	●	●	●	○	K01
	82-2 (A)			3/4 in 11T 16/32DP ⁴⁾	○	○	○	○	○	●	○	○	○	K52
	101-2 (B)			7/8 in 13T 16/32DP ⁴⁾	●	●	●	●	●	●	●	●	○	K68
	101-2 (B)			1 in 15T 16/32DP ⁴⁾	●	●	●	●	●	●	●	○	○	K04
	127-2 (C)			1 1/4 in 14T 12/24DP ⁴⁾	-	●	●	●	●	●	●	●	●	K07
	127-2 (C)			1 1/2 in 17T 12/24DP ⁴⁾	-	-	●	●	●	●	●	●	●	K24
	152-4 (D)			1 3/4 in 13T 8/16DP ⁴⁾	-	-	●	●	●	●	●	●	○	K17
	Prepared for through drive, with pressure-proof plugged cover				●	●	●	●	●	●	●	●	●	K99
	Boost pump⁶⁾													
	A piped attachment pump for the boost circuit				●	●	●	●	▲	▲	▲	▲	●	H02
	A shared piped attachment pump for the boost and control circuit (only for EO1 and EO1K)				●	●	●	-	-	-	-	▲	-	H04
	A separate piped attachment pump for the boost circuit and the control circuit (only for HD1T and HD1U) including pressure relief valve for the control circuit				●	●	●	●	▲	▲	▲	▲	●	H06

● = Available ○ = On request - = Not available ▲ = Not for new projects

3) According to DIN 5480
 4) According to ANSI B92.1a
 5) Mounting hole pattern viewed on through drive with control at top.

6) For boost pump attachment NG250 to 750, please use A4CSG. (see data sheet 92105). An overview of the available boost pumps for the NG40 to 180 and 1000 can be found on page 47.

4 **A4VSG Series 1x and 3x** | Axial piston variable pump
Type code

01	02	03	04	05	06	07	08	09	10	11	12	13	14
	A4VS	G			/			-				10	

Valves		40	71	125	180	250	355	500	750	1000	
13	Without valve block	●	●	●	●	●	●	●	●	●	0
	Valve block mounted SDVB Data sheet 95533	▲	▲	▲	▲	▲ ⁹⁾	▲ ⁹⁾	▲ ⁹⁾	▲ ⁹⁾	●	9
	Valve block mounted SDVB 16 (With direct-controlled flushing slide and pilot operated high-pressure relief valve) in preparation	●	●	●	●	-	-	-	-	-	4

Filtration		40	71	125	180	250	355	500	750	1000	
14	Without filter	●	●	●	●	●	●	●	●	●	N
	Filter mounted in boost circuit	●	●	●	●	●	●	●	○	○	F⁷⁾
	Intermediate plate filter (for HS- and DS-control, see data sheet 92076 and 92058)	●	●	●	●	●	●	● ⁸⁾	●	●	Z
	Filter mounted in boost circuit and intermediate plate filter for HS-controls	●	●	●	●	●	●	● ⁸⁾	-	-	U

● = Available ○ = On request - = Not available

▲ = Not for new projects

Notices

- ▶ Note the project planning notes on page 54.
- ▶ In addition to the type code, please specify the relevant technical data when placing your order.
- ▶ For details of the mounting situation of combination pumps, see page 45.

7) Filter in the boost circuit with visual-electrical contamination indicator in standard version for:

- NG40, 71: LFBN/HC60G20D1.0/V-L24
- NG125, 180: LFBN/HC110G20D1.0/V-L24
- NG250, 355: LFBN/HC240G20D1.0/V-L24
- NG500: LFBN/HC330G20D1.0/V-L24
- NG750, 1000: LFBN/HC660G20D1.0/V-L24

Please contact us for more information on the filter.

8) For size 500, only available for DS control; for HS, see data sheet 92076

9) For valve block attachment NG250 to 750, please use A4CSG. (see data sheet 92105).

Hydraulic fluids

The A4VSG variable pump is designed for operation with HLP mineral oil according to DIN 51524.

Application instructions and requirements for hydraulic fluids should be taken from the following data sheets before the start of project planning:

- ▶ 90220: Hydraulic fluids based on mineral oils and related hydrocarbons
- ▶ 90221: Environmentally acceptable hydraulic fluids
- ▶ 90222: Fire-resistant, water-free hydraulic fluids (HFDR/HFDU)

Notes on selection of hydraulic fluid

The hydraulic fluid should be selected so that the operating viscosity in the operating temperature range is within the optimum range (v_{opt} see selection diagram).

Viscosity and temperature of hydraulic fluids

	Viscosity	Shaft seal	Temperature ³⁾	Comment
Cold start	$v_{max} \leq 1600 \text{ mm}^2/\text{s}$	NBR ²⁾	$\theta_{St} \geq -40 \text{ }^\circ\text{C}$	$t \leq 3 \text{ min}$, without load ($p \leq 50 \text{ bar}$), $n \leq 1000 \text{ rpm}$ Permissible temperature difference between axial piston unit and hydraulic fluid in the system maximum 25 K
		FKM	$\theta_{St} \geq -25 \text{ }^\circ\text{C}$	
Warm-up phase	$v = 1600 \dots 400 \text{ mm}^2/\text{s}$			$t \leq 15 \text{ min}$, $p \leq 0.7 \times p_{nom}$ and $n \leq 0.5 \times n_{nom}$
Continuous operation	$v = 400 \dots 10 \text{ mm}^2/\text{s}^{1)}$	NBR ²⁾	$\theta \leq +85 \text{ }^\circ\text{C}$	measured at port T
		FKM	$\theta \leq +110 \text{ }^\circ\text{C}$	
	$v_{opt} = 36 \dots 16 \text{ mm}^2/\text{s}$			Range of optimum operating viscosity and efficiency
Short-term operation	$v_{min} = 10 \dots 7 \text{ mm}^2/\text{s}$	NBR ²⁾	$\theta \leq +85 \text{ }^\circ\text{C}$	$t \leq 3 \text{ min}$, $p \leq 0.3 \times p_{nom}$, measured at port T
		FKM	$\theta \leq +110 \text{ }^\circ\text{C}$	

▼ Selection diagram

Maximum permissible viscosity for cold start

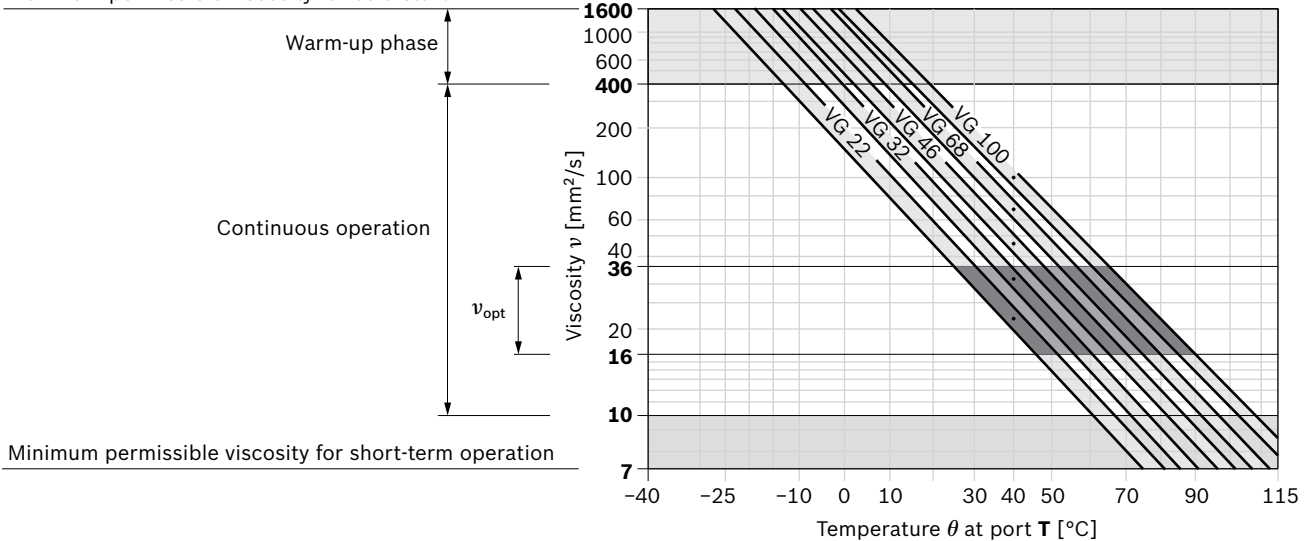

1) This corresponds, for example on VG 46, to a temperature range of +4 °C to +85 °C (see selection diagram)

2) Special version, please contact us

3) If the temperature at extreme operating parameters cannot be adhered to, please contact us.

Filtration of the hydraulic fluid

Finer filtration improves the cleanliness level of the hydraulic fluid, which increases the service life of the axial piston unit. A cleanliness level of at least 20/18/15 is to be maintained according to ISO 4406.

At a hydraulic fluid viscosity of less than 10 mm²/s (e.g. due to high temperatures during short-time duty) at the drain port, a cleanliness level of at least 19/17/14 according to ISO 4406 is required.

For example, the viscosity corresponds to 10 mm²/s:

- at a temperature of 73 °C for HLP 32
- at a temperature of 85 °C for HLP 46

Bearing flushing

For the following operating conditions bearing flushing is required for a safe, continuous operation:

- ▶ Applications with water-containing special fluids due to limited lubricity and narrow operating temperature range
- ▶ Operation with borderline conditions for temperature and viscosity
- ▶ With vertical installation (drive shaft facing upwards) for lubricating the front bearing and the shaft seal.

Bearing flushing is realized at port **U** in the area of the front flange of the variable pump. The flushing fluid flows through the front bearing and discharges with the pump drain at the drain port.

Depending on the individual sizes, the following flushing flows are recommended:

NG	40	71	125	180	250	355	500	750	1000
q_{Sp} l/min	3	4	5	7	10	15	20	30	40

For the flushing flows stated, there is a pressure differential of about 2 or 3 bar between port **U** (including fitting) and the case drain chamber (series 1x and series 3x, respectively).

Notice regarding series 3x

When using external bearing flushing, the throttle screw in port **U** must be turned to the stop.

Shaft seal

Permissible pressure load

The service life of the shaft seal ring is influenced by the rotational speed of the pump and the leakage pressure. It is recommended that the average, continuous leakage pressure of 2 bar absolute at operating temperature not be exceeded (maximum permissible leakage pressure 4 bar absolute at reduced rotational speed, see diagram). Short-term ($t < 0.1$ s) pressure peaks of up to 10 bar absolute are permitted. The service life of the shaft seal ring decreases with an increase in the frequency of pressure peaks. The case pressure must be equal to or greater than the external pressure on the shaft seal.

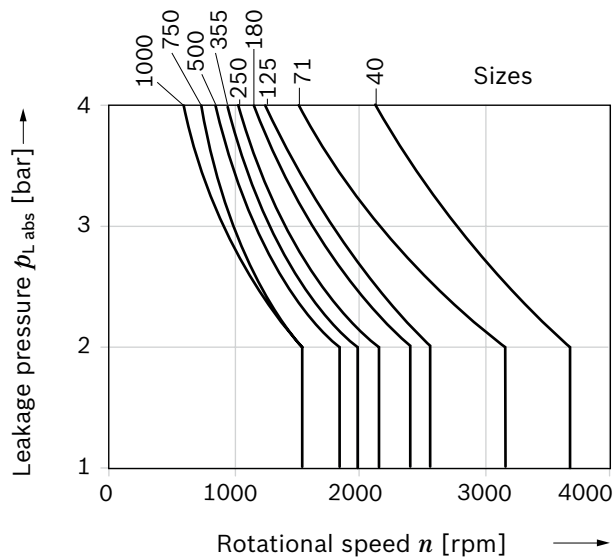

Notice

For details on the viscosity and temperatures of the hydraulic fluids, please see page 5.

Flow direction

Direction of rotation		Swiveling range
clockwise	counter-clockwise	
B to A	A to B	clockwise
A to B	B to A	counter-clockwise

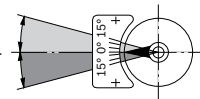

Working pressure range

Pressure at working port A or B		Definition
Nominal pressure p_{nom}	350 bar	The nominal pressure corresponds to the maximum design pressure.
Maximum pressure p_{max}	400 bar	The maximum pressure corresponds to the maximum working pressure within the single operating period. The sum of the single operating periods must not exceed the total operating period.
Single operating period	1 s	
Total operating period	300 h	
Minimum pressure (High-pressure side)	15 bar	Minimum pressure at the high-pressure side (A or B) which is required to prevent damage to the axial piston unit.
Minimum pressure (low-pressure side)		Minimum pressure at the low-pressure side (A or B) which is required to prevent damage to the axial piston unit. The minimum pressure depends on the rotational speed and the feed pressure (see diagram).
Rate of pressure change $R_{A\ max}$	16000 bar/s	Maximum permissible speed of pressure build-up and reduction during a pressure change across the entire pressure range.
Recommended boost pressure p_{SP} (input) (for boost pumps, see page 47)		
Sizes 40 to 500	16 bar	
Sizes 750 to 1000	25 bar	
for a shared attachment pump for boost and control fluid circuit (EO1...Ho4)	25 bar	
Maximum boost pressure - attachment pump $p_{S\ max}$ at control ¹⁾ :		
MA, EM, HM, EO, DS	50 bar	For information on the control pressure, see the respective data sheets on page 2
HD, EP	25 bar	
Case pressure at port K₂, K₃, R(L)		
Maximum static pressure $p_{L\ max}$	3 bar	Maximum 1.2 bar higher than inlet pressure at port S, but not higher than $p_{L\ max}$. A drain line to the reservoir is required.
Pressure peaks $p_{L\ peak}$	6 bar	$t < 0.1$ s

▼ Rate of pressure change $R_{A\ max}$

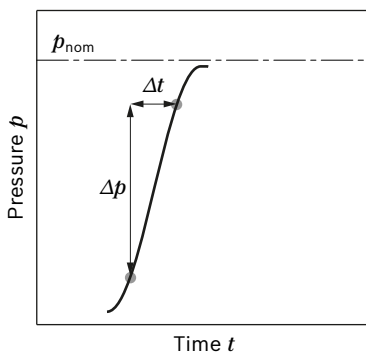

▼ Minimum pressure, low-pressure side

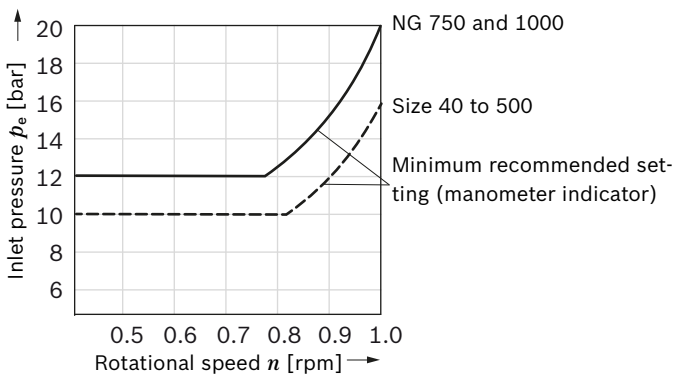

▼ Pressure definition

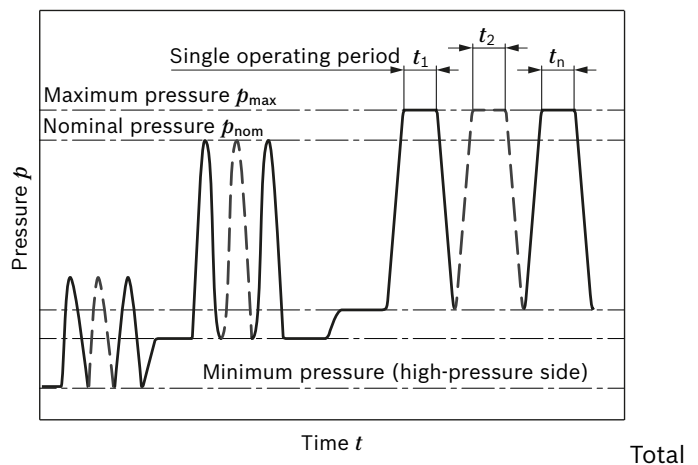

$$\text{Operating period} = t_1 + t_2 + \dots + t_n$$

Notice

Working pressure range valid when using hydraulic fluids based on mineral oils. Please contact us for values for other hydraulic fluids.

1) For permissible inlet pressure of the respective attachment pump, see the corresponding data sheet

Technical data

Size	NG	40	71	125	180	250	355	500	750	1000
Displacement, geometric, per revolution	$V_{g \max}$ cm ³	40	71	125	180	250	355	500	750	1000
Rotational speed maximum ¹⁾	at $V_{g \max}$ n_{\max} rpm	3700	3200	2600	2400	2200	2000	1800	1600	1600
Flow	at n_{\max} and $V_{g \max}$ q_v l/min	148	227	325	432	550	710	900	1200	1600
	at 1500 rpm and $V_{g \max}$	60	107	186	270	375	533	750	1125	1500
Power	at n_{\max} , $V_{g \max}$ and $\Delta p = 350$ bar P kW	86	132	190	252	321	414	525	700	933
	at 1500 rpm, $V_{g \max}$ and $\Delta p = 350$ bar	35	62	109	158	219	311	438	656	875
Torque	at $V_{g \max}$ and $\Delta p = 350$ bar M Nm	223	395	696	1002	1391	1976	2783	4174	5565
	at $V_{g \max}$ and $\Delta p = 100$ bar	64	113	199	286	398	564	795	1193	1590
Rotary stiffness of drive shaft	P c kNm/rad	80	146	260	328	527	800	1145	1860	2730
	Z c kNm/rad	77	146	263	332	543	770	1136	1812	2845
Moment of inertia Rotary group	J_{TW} kgm ²	0.0049	0.0121	0.03	0,055	0.0959	0.19	0.3325	0.66	1.20
Maximum angular acceleration ²⁾	α rad/s ²	17000	11000	8000	6800	4800	3600	2800	2000	1450
Case volume	V l	2	2.5	5	4	10	8	14	19	27
Weight approx.	m kg	42	60	107	112	220	235	335	500	644

Determining the characteristics	
Flow	$q_v = \frac{V_g \times n \times \eta_v}{1000}$ [l/min]
Torque	$M = \frac{V_g \times \Delta p}{20 \times \pi \times \eta_{hm}}$ [Nm]
Power	$P = \frac{2 \pi \times M \times n}{60000} = \frac{q_v \times \Delta p}{600 \times \eta_t}$ [kW]
Key	
V_g	= Displacement per revolution [cm ³]
Δp	= Differential pressure [bar]
n	= Rotational speed [rpm]
η_v	= Volumetric efficiency
η_{hm}	= Hydraulic-mechanical efficiency
η_t	= Total efficiency ($\eta_t = \eta_v \times \eta_{hm}$)

Notices

- ▶ Theoretical values, without efficiency and tolerances; values rounded
- ▶ Operation above the maximum values or below the minimum values may result in a loss of function, a reduced service life or in the destruction of the axial piston unit. We recommend testing the loads by means of experiment or calculation / simulation and comparison with the permissible values.

- 1) The values are applicable:
 - for the optimum viscosity range from $v_{opt} = 36$ to 16 mm²/s
 - with hydraulic fluid based on mineral oils
- 2) The data are valid for values between the minimum required and maximum permissible rotational speed. Valid for external excitation (e.g. diesel engine 2 to 8 times rotary frequency; cardan shaft twice the rotary frequency). The limit value is only valid for a single pump. The load capacity of the connecting parts must be considered.

Permissible radial and axial forces of the drive shafts

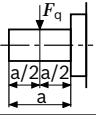
Size	NG	40	71	125	180	250	355	500	750	1000		
Maximum radial force at distance a/2		$F_{q \max}$	N	1000	1200	1600	2000	2000	2200	2500	3000	3500
Maximum axial force		$+ F_{ax \max}$	N	600	800	1000	1400	1800	2000	2000	2200	2200
		$- F_{ax \max}$	N									

Notices

- ▶ Special requirements apply in the case of belt drives. Please contact us.
- ▶ Force-transfer direction of the permissible axial force
 - + $F_{ax \max}$ = Increase in bearing service life
 - $F_{ax \max}$ = Reduction in bearing service life

Permissible input and through-drive torques

Size	NG	40	71	125	180	250	355	500	750	1000			
Torque at $V_{g \max}$ and $\Delta p = 350 \text{ bar}^1$	M_{\max}	Nm	223	395	696	1002	1391	1976	2783	4174	5565		
Maximum input torque at drive shaft ²⁾													
	Splined shaft	Z	$M_{E \max}$	Nm	446	790	1392	2004	2782	3952	5566	8348	11130
	Shaft key	P	$M_{E \max}$	Nm	380	700	1392	1400	2300	3557	5200	7513	9444
Maximum through-drive torque	$M_{D \max}$	Nm	$T_{D \max} = T_{E \max}$										

▼ **Distribution of torques**

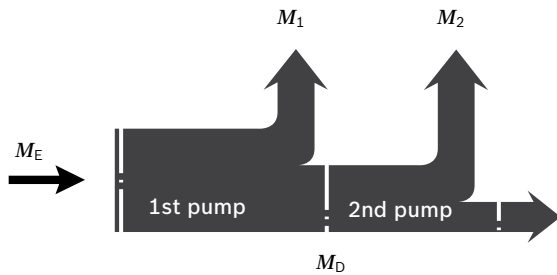

Torque at 1st pump	M_1
Torque at 2nd pump	M_2
Torque at 3rd pump	M_3
Input torque	$M_E = M_1 + M_2 + M_3$
	$M_E < M_{E \max}$
Through-drive torque	$M_D = M_2 + M_3$
	$M_D < M_{D \max}$

1) Efficiency not considered

2) For drive shafts free of radial force

Overview of control device

Hydraulic control HM 1/2, volume dependent (see data sheet 92076)

The pump displacement can be steplessly adjusted in relation to the pilot oil volume in ports **X₁** and **X₂**.

Application:

- ▶ 2-point circuit
- ▶ Base device for servo or proportional controls

▼ HM1 NG125 schematic

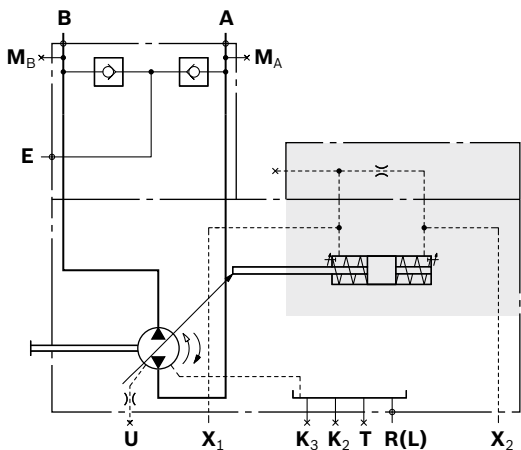

Control system HS., HS5., with servo or proportional valve (see RE 92076)

The stepless displacement control is accomplished by means of a servo or proportional valve and electrical feedback of the swivel angle.

The HS5P control system is equipped with a mounted pressure transducer, which means that it can be used for electric pressure and power control.

Optional:

- ▶ Servo valve (HS);
- ▶ Proportional valve (HS5)
- ▶ With integrated control pressure supply (HS5V);
- ▶ Control system with integrated digital electronics OBE (HS5E)
- ▶ Short circuit valve (HSK, HS5K, HS5KP);
- ▶ For oil-immersed use (HS5M)

▼ Characteristic curve HS5

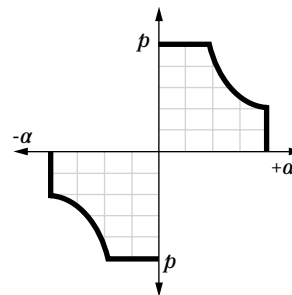

▼ HS5P NG500 schematic

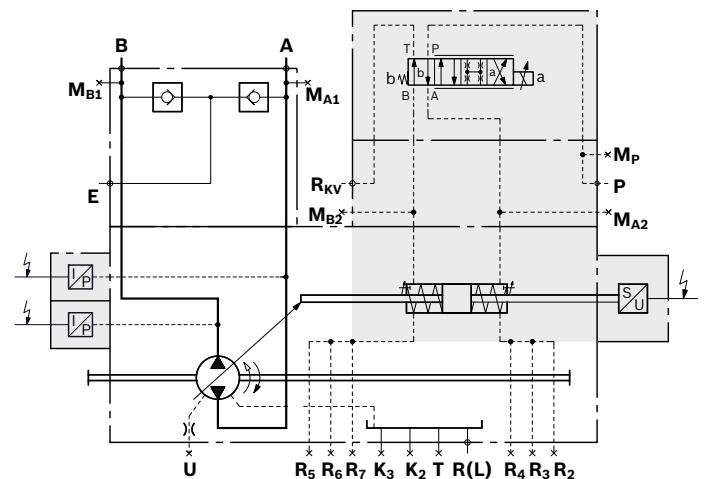

Control system EO1/2
 (see RE 92076)

The stepless control of the displacement flow is accomplished by means of a proportional valve and electrical feedback of the swivel angle. Thus, the control can be used as an electric displacement control.

Optional:

- ▶ Control pressure range (EO1, EO2)
- ▶ Short circuit valve (EO1K, EO2K)

▼ **Characteristic curve EO**

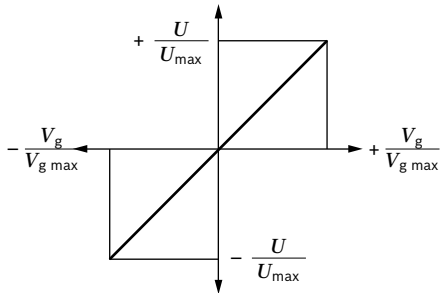

▼ **HM1 NG125 schematic**

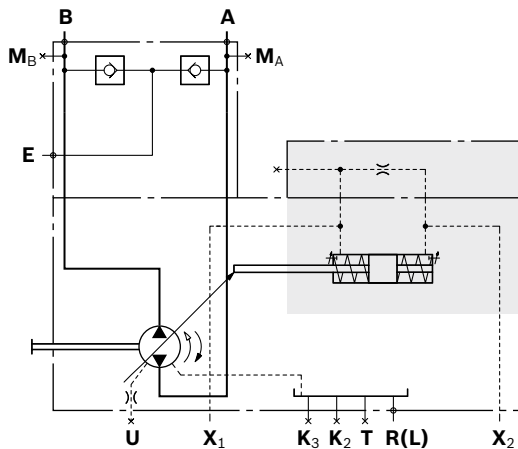

Hydraulic control HD, pilot-pressure related
 (see data sheet 92080)

Stepless adjustment of the pump displacement according to the pilot pressure. The control is proportional to the specified pilot pressure (difference between pilot pressure and case pressure).

Optional:

- ▶ Control characteristics (HD1, HD2, HD3)
- ▶ Pressure control (HD.B),
- ▶ Remote pressure control (HD.GB)
- ▶ Power control (HD1P)
- ▶ Electrical control of pilot pressure (HD1T)

▼ **Characteristic curve HD**

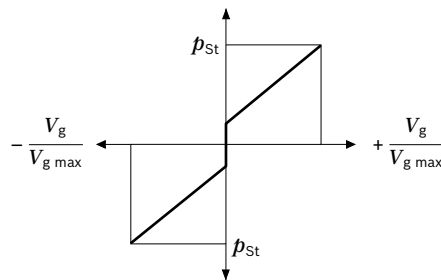

▼ **Schematic HD**

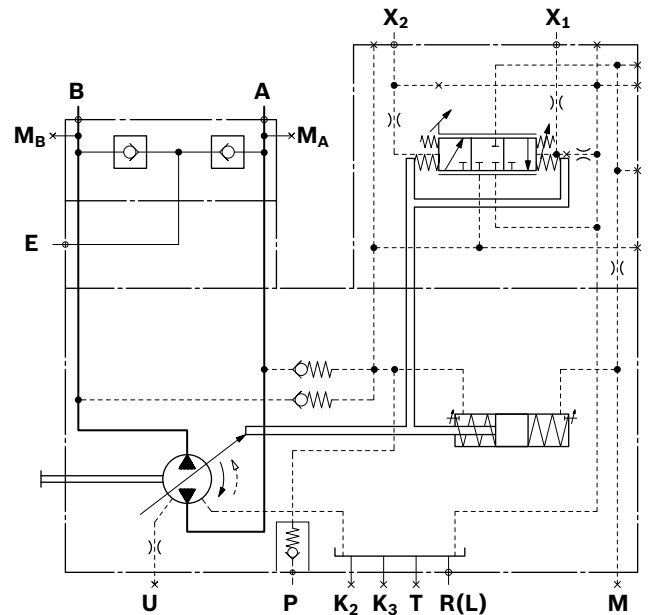

**Electrohydraulic control EP with proportional solenoid
 (see data sheet 92084)**

The EP control adjusts the pump displacement proportionally to the current at the solenoid. Current-regulated control units with pulse-width modulation are recommended for controlling the solenoids.

Optional:

- ▶ Pressure control (EPA, EPB, EPD)
- ▶ Remote pressure control (EPGA, EPGB, EPG)

▼ **Characteristic curve EP**

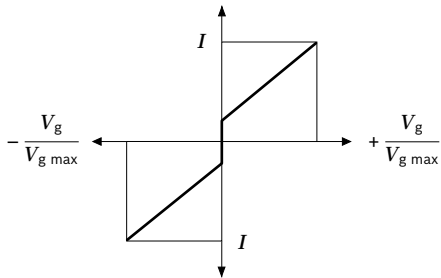

▼ **Circuit diagram EP**

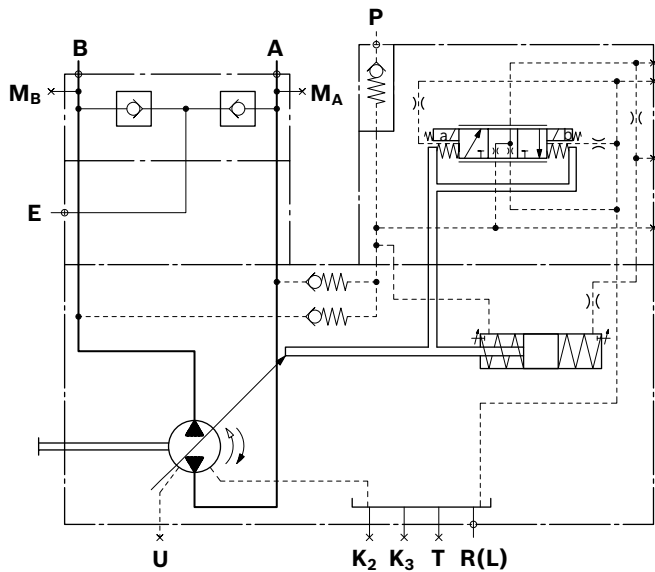

DS2 secondary speed control
 (see RE 92058)

The speed control DS2 controls the secondary unit (motor) in such a manner, that this motor delivers sufficient torque to maintain the required rotational speed.
 When connected to a constant pressure system, this torque is proportional to the displacement and thus also proportional to the swivel angle.

▼ **Characteristic curve DS2**

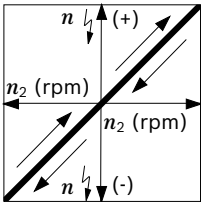

▼ **Circuit diagram DS2**

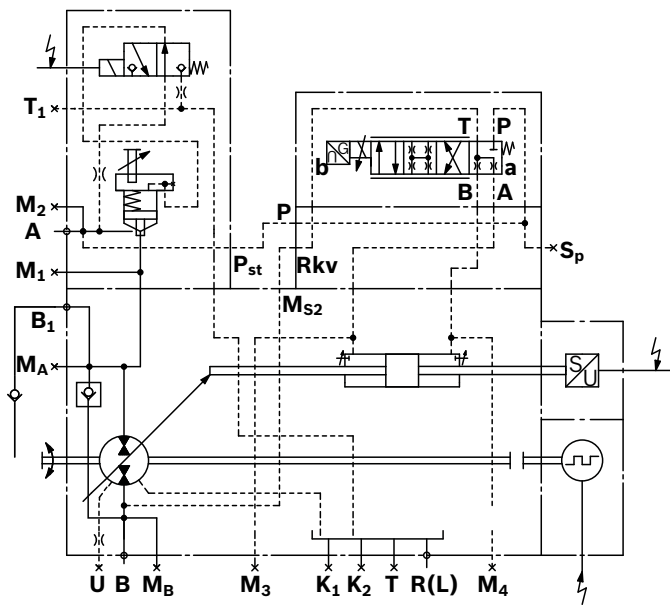

Dimensions, size 40

Example: **HM – Hydraulic control, control volume dependent**, for additional dimensions, see data sheets for the controls

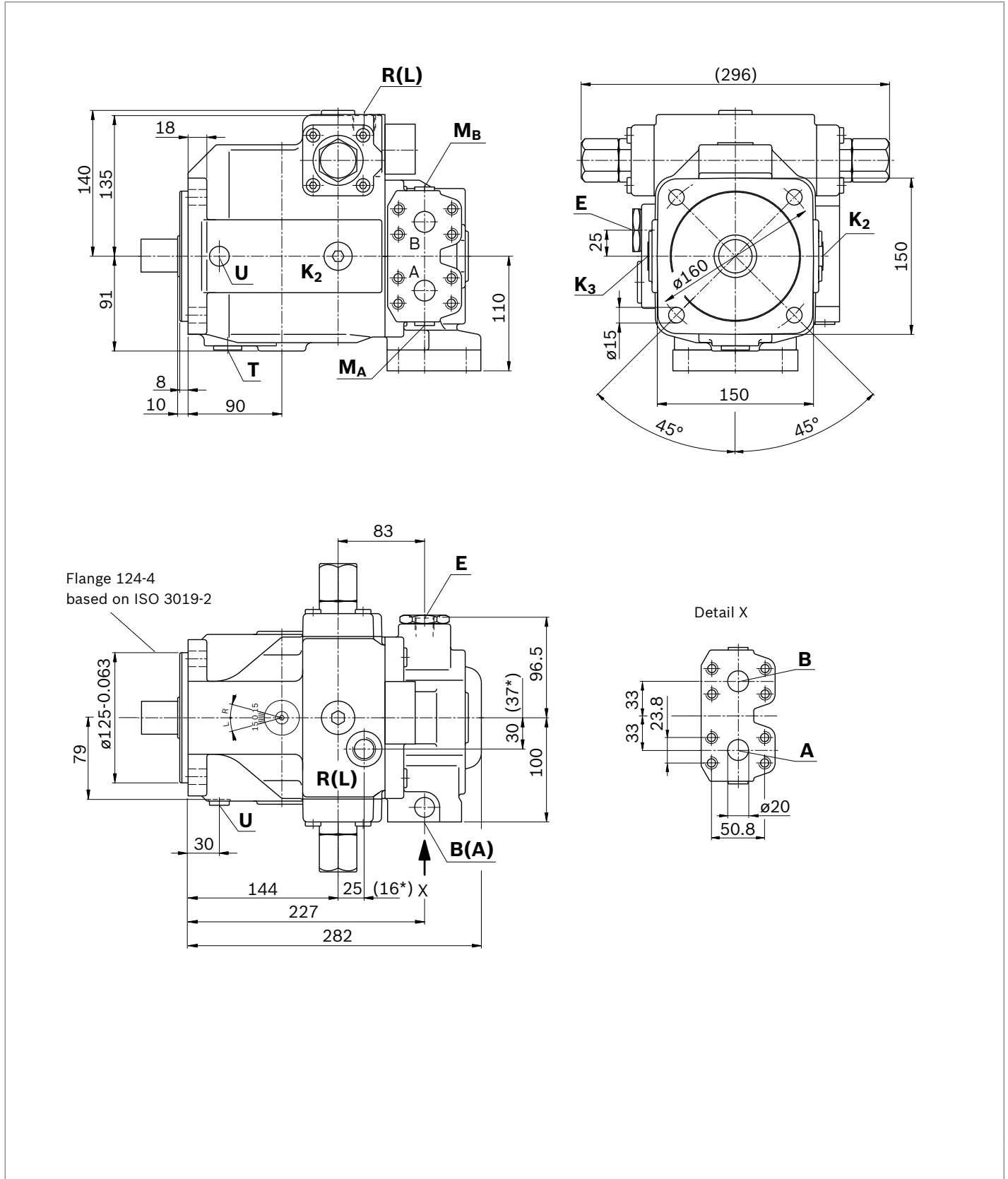

▼ Splined shaft DIN 5480

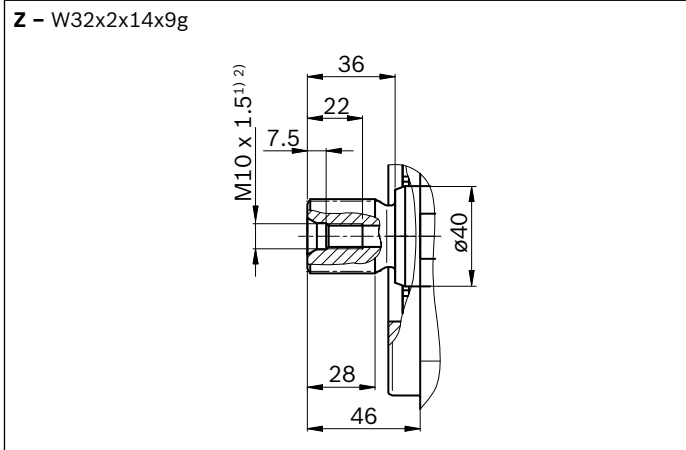

▼ Parallel keyed shaft DIN 6885

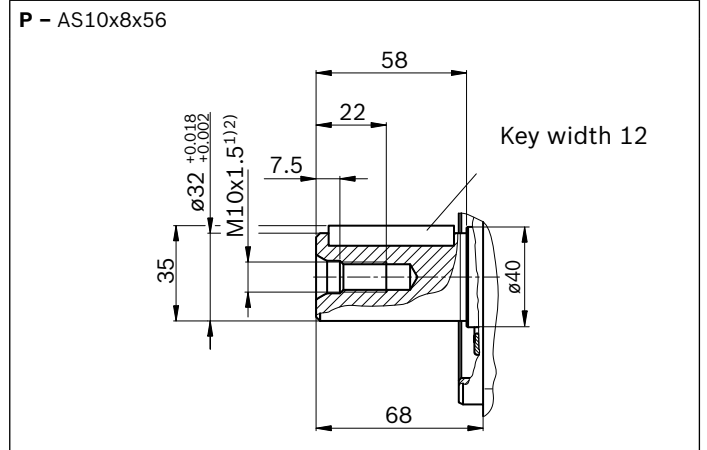

Ports		Standard	Size ²⁾	$p_{\max \text{ abs}}$ [bar] ³⁾	State ⁷⁾
A, B	Working port (high-pressure series) Fastening thread	SAE J518 ⁴⁾ DIN 13	3/4 in M10 × 1.5; 17 deep	400	O
M_A, M_B	Measuring working pressure A/B	DIN 3852	M14 × 1.5; 12 deep	400	X
T	Fluid drain	DIN 3852 ⁵⁾	M22 × 1.5; 14 deep	4	X ⁶⁾
E	Boost pressure supply	DIN 3852	M18 × 1.5; 12 deep	50	O
K₂, K₃	Filling – air bleeding, return flow (drain port)	DIN 3852 ⁵⁾	M22 × 1.5; 14 deep	4	X ⁶⁾
R(L)	Filling – air bleeding, return flow (drain port)	DIN 3852 ⁵⁾	M22 × 1.5; 14 deep	4	O ⁶⁾
U	Bearing flushing	DIN 3852 ⁵⁾	M14 × 1.5; 12 deep	7	X

- Center bore according to DIN 332 (thread according to DIN 13)
- Observe the instructions in the instruction manual concerning the maximum tightening torques.
- Depending on the application, momentary pressure peaks can occur. Keep this in mind when selecting measuring devices and fittings.
- Metric fastening thread is a deviation from standard.

- The countersink can be deeper than as specified in the standard.
- Depending on the installation position, T₁, K₂, K₃ or R(L) must be connected (see also installation instructions on pages 50 and 52).
- O = Must be connected (plugged when delivered)
X = Plugged (in normal operation)

Dimensions, size 71

Example: **HM – Hydraulic control, control volume dependent**, for additional dimensions, see data sheets for the controls

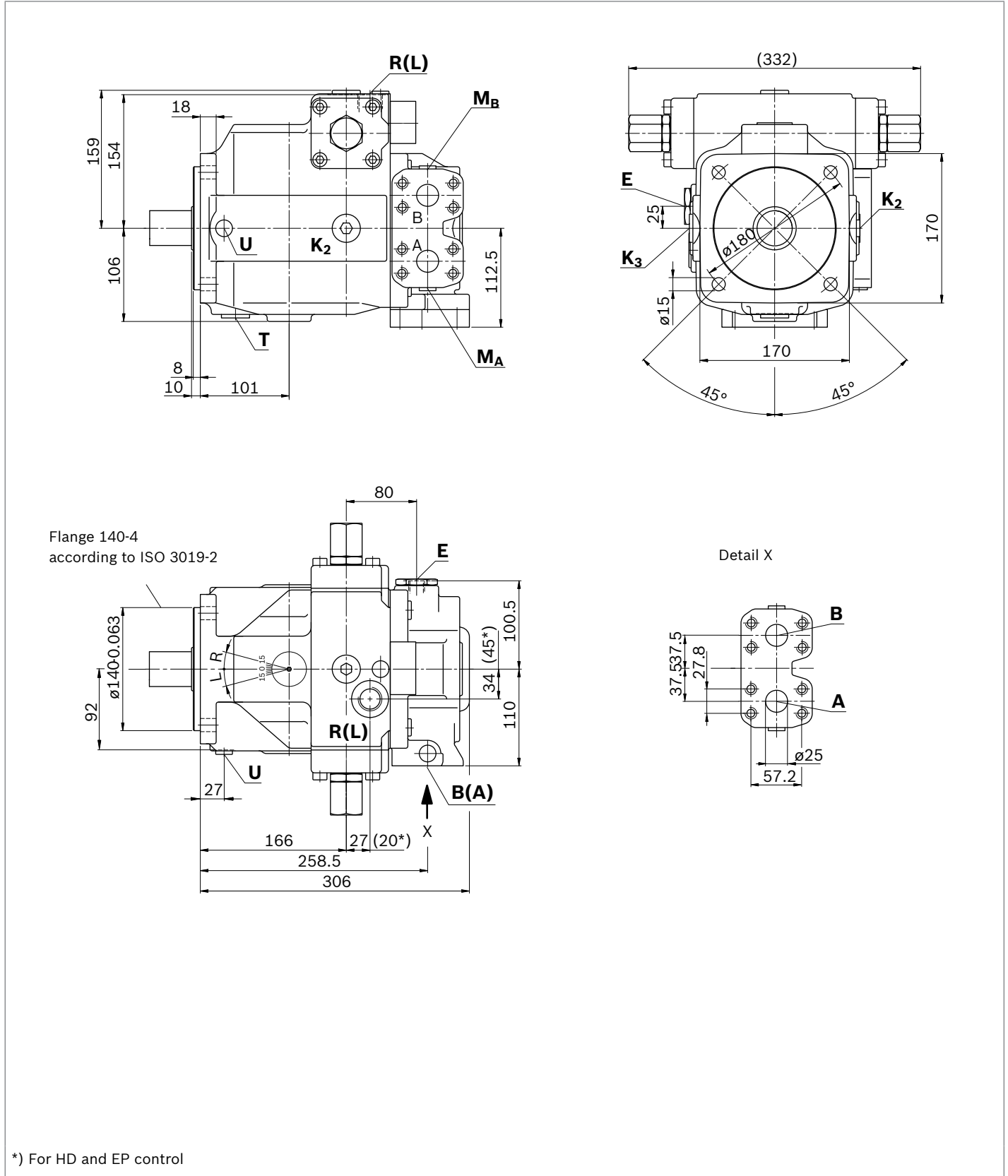

▼ **Splined shaft DIN 5480**

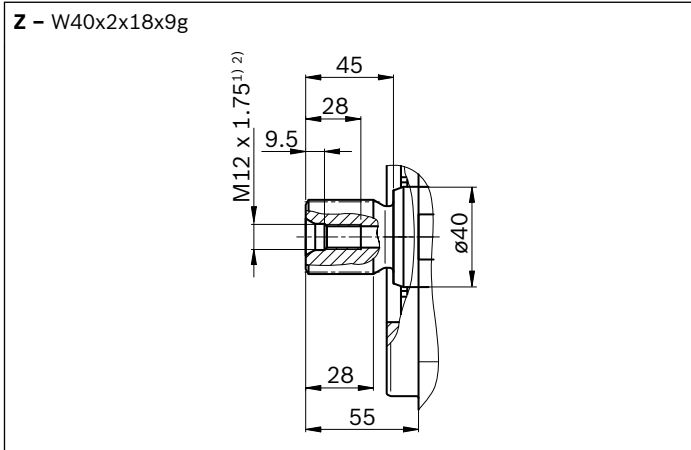

▼ **Parallel keyed shaft DIN 6885**

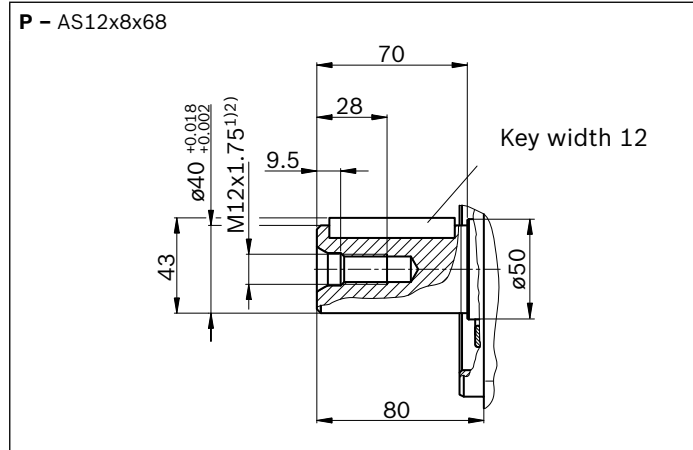

Ports		Standard	Size ²⁾	$p_{max\ abs}$ [bar] ³⁾	State ⁷⁾
A, B	Working port (high-pressure series) Fastening thread	SAE J518 ⁴⁾ DIN 13	1 in M12 × 1.75; 17 deep	400	O
M_A, M_B	Measuring working pressure A/B	DIN 3852	M14 × 1.5; 12 deep	400	X
T	Fluid drain	DIN 3852 ⁵⁾	M27 × 2; 16 deep	4	X ⁶⁾
E	Boost pressure supply	DIN 3852	M18 × 1.5; 12 deep	50	O
K₂, K₃	Filling – air bleeding, return flow (drain port)	DIN 3852 ⁵⁾	M27 × 2; 16 deep	4	X ⁶⁾
R(L)	Filling – air bleeding, return flow (drain port)	DIN 3852 ⁵⁾	M27 × 2; 16 deep	4	O ⁶⁾
U	Bearing flushing	DIN 3852 ⁵⁾	M14 × 1.5; 12 deep	7	X

1) Center bore according to DIN 332 (thread according to DIN 13)
 2) Observe the instructions in the instruction manual concerning the maximum tightening torques.
 3) Depending on the application, momentary pressure peaks can occur. Keep this in mind when selecting measuring devices and fittings.
 4) Metric fastening thread is a deviation from standard.

5) The countersink can be deeper than as specified in the standard.
 6) Depending on the installation position, T₁, K₂, K₃ or R(L) must be connected (see also installation instructions on pages 50 and 52).
 7) O = Must be connected (plugged when delivered)
 X = Plugged (in normal operation)

Dimensions, size 125

Example: **HM.** – Hydraulic control, control volume dependent, for additional dimensions, see data sheets for the controls

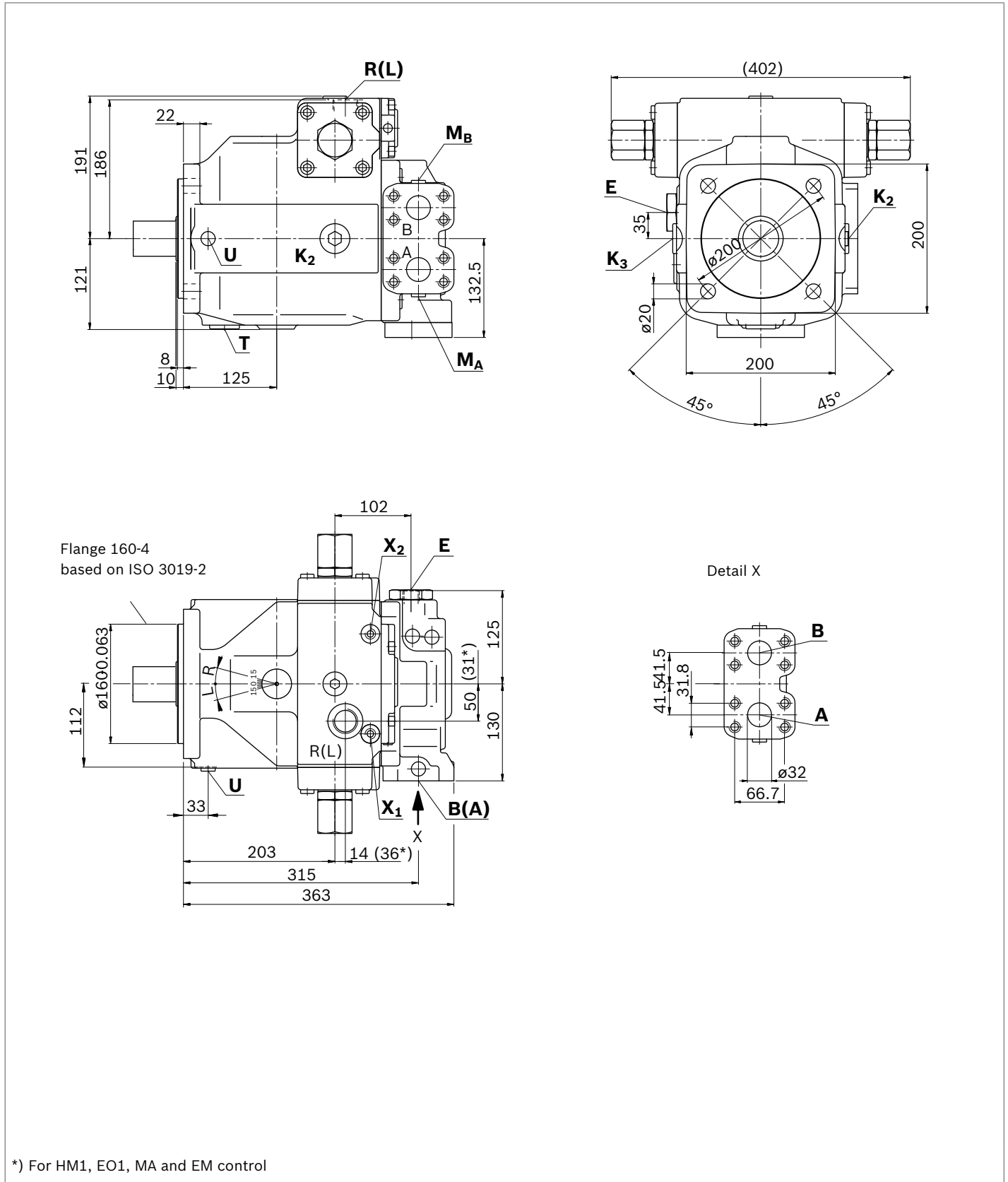

▼ Splined shaft DIN 5480

Z – W50x2x24x9g

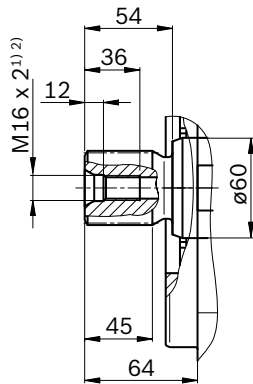

▼ Parallel keyed shaft DIN 6885

P – AS14x9x80

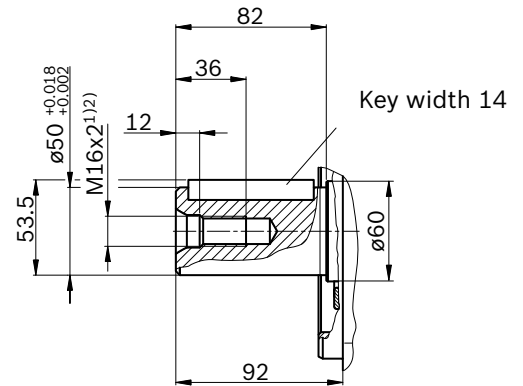

Ports		Standard	Size ²⁾	$p_{\max \text{ abs}}$ [bar] ³⁾	State ⁷⁾
A, B	Working port (high-pressure series) Fastening thread	SAE J518 ⁴⁾ DIN 13	1 1/4 in M14 × 2; 19 deep	400	O
M_A, M_B	Measuring working pressure A/B	DIN 3852	M14 × 1.5; 12 deep	400	X
T	Fluid drain	DIN 3852 ⁵⁾	M33 × 2; 18 deep	4	X ⁶⁾
E	Boost pressure supply	DIN 3852	M22 × 1.5; 14 deep	50	O
X₁, X₂	Control pressure (for HM1)	DIN 3852	M14 × 1.5; 12 deep	100	O
X₁, X₂	Control pressure (for HM2)	DIN 3852	M18 × 1.5; 12 deep	350	O
K₂, K₃	Filling – air bleeding, return flow (drain port)	DIN 3852 ⁵⁾	M33 × 2; 18 deep	4	X ⁶⁾
R(L)	Filling – air bleeding, return flow (drain port)	DIN 3852 ⁵⁾	M33 × 2; 18 deep	4	O ⁶⁾
U	Bearing flushing	DIN 3852 ⁵⁾	M14 × 1.5; 12 deep	7	X

- Center bore according to DIN 332 (thread according to DIN 13)
- Observe the instructions in the instruction manual concerning the maximum tightening torques.
- Depending on the application, momentary pressure peaks can occur. Keep this in mind when selecting measuring devices and fittings.
- Metric fastening thread is a deviation from standard.

- The countersink can be deeper than as specified in the standard.
- Depending on the installation position, T₁, K₂, K₃ or R(L) must be connected (see also installation instructions on pages 50 and 52).
- O = Must be connected (plugged when delivered)
X = Plugged (in normal operation)

Dimensions, size 180

Example: **HM. – Hydraulic control, control volume dependent**, for additional dimensions, see data sheets for the controls

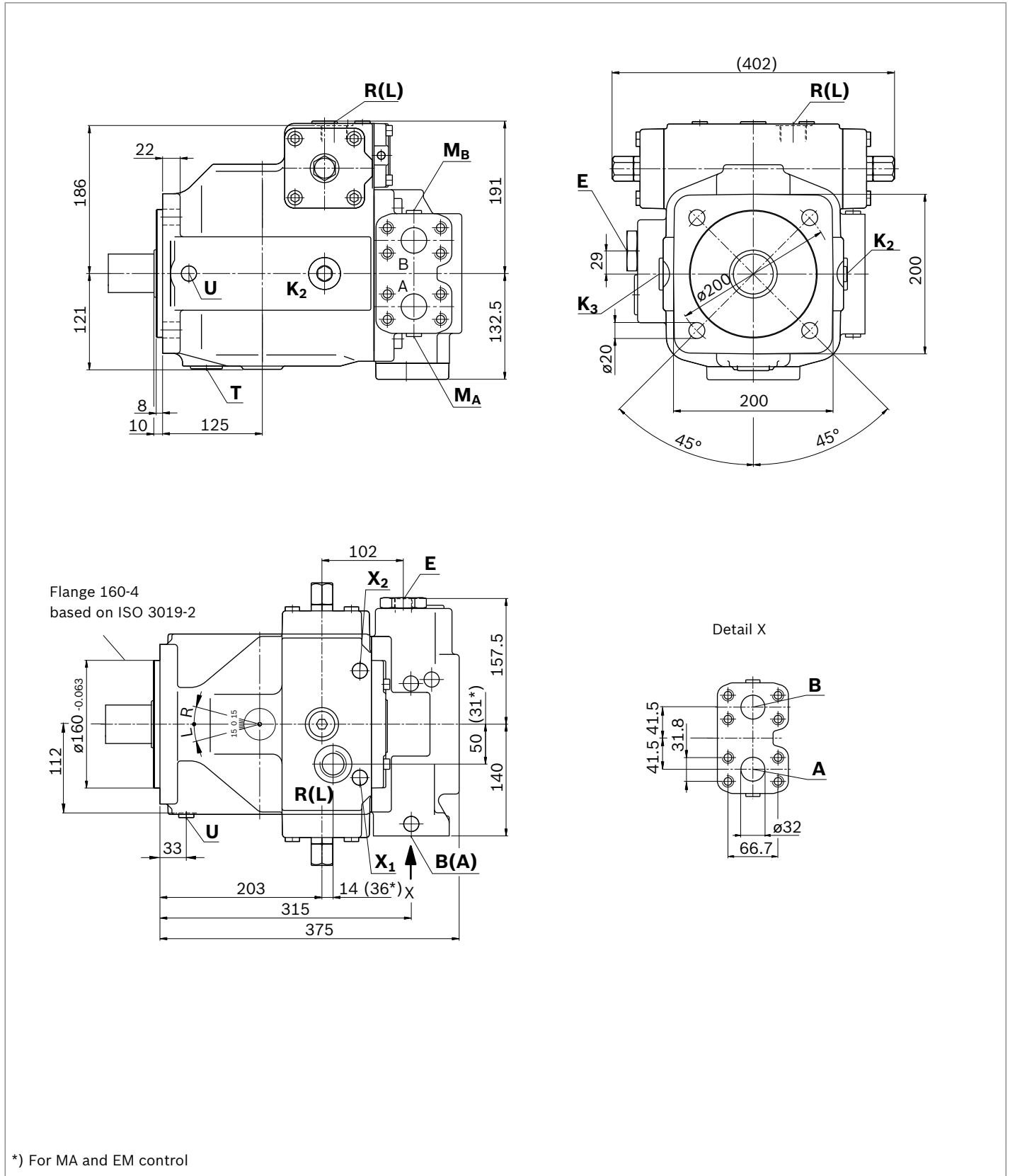

▼ Splined shaft DIN 5480

Z – W50x2x24x9g

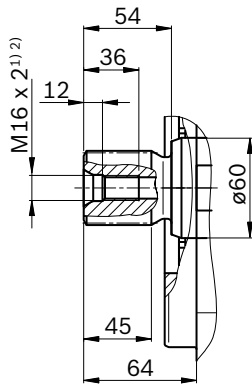

▼ Parallel keyed shaft DIN 6885

P – AS14x9x80

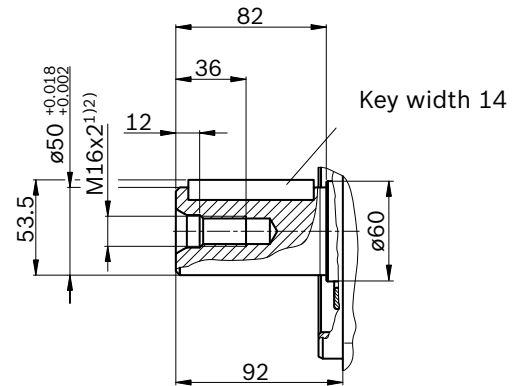

Ports		Standard	Size ²⁾	$p_{\max \text{ abs}}$ [bar] ³⁾	State ⁷⁾
A, B	Working port (high-pressure series) Fastening thread	SAE J518 ⁴⁾ DIN 13	1 1/4 in M14 × 2; 19 deep	400	O
M_A, M_B	Measuring working pressure A/B	DIN 3852	M14 × 1.5; 12 deep	400	X
T	Fluid drain	DIN 3852 ⁵⁾	M33 × 2; 18 deep	4	X ⁶⁾
E	Boost pressure supply	DIN 3852	M22 × 1.5; 14 deep	50	O
X₁, X₂	Control pressure (for HM1)	DIN 3852	M14 × 1.5; 12 deep	100	O
X₁, X₂	Control pressure (for HM2)	DIN 3852	M18 × 1.5; 12 deep	350	O
K₂, K₃	Filling – air bleeding, return flow (drain port)	DIN 3852 ⁵⁾	M33 × 2; 18 deep	4	X ⁶⁾
R(L)	Filling – air bleeding, return flow (drain port)	DIN 3852 ⁵⁾	M33 × 2; 18 deep	4	O ⁶⁾
U	Bearing flushing	DIN 3852 ⁵⁾	M14 × 1.5; 12 deep	7	X

- Center bore according to DIN 332 (thread according to DIN 13)
- Observe the instructions in the instruction manual concerning the maximum tightening torques.
- Depending on the application, momentary pressure peaks can occur. Keep this in mind when selecting measuring devices and fittings.
- Metric fastening thread is a deviation from standard.

- The countersink can be deeper than as specified in the standard.
- Depending on the installation position, T₁, K₂, K₃ or R(L) must be connected (see also installation instructions on pages 50 and 52).
- O = Must be connected (plugged when delivered)
X = Plugged (in normal operation)

Dimensions, size 250

Example: **HM**. – Hydraulic control, control volume dependent, for additional dimensions, see data sheets for the controls

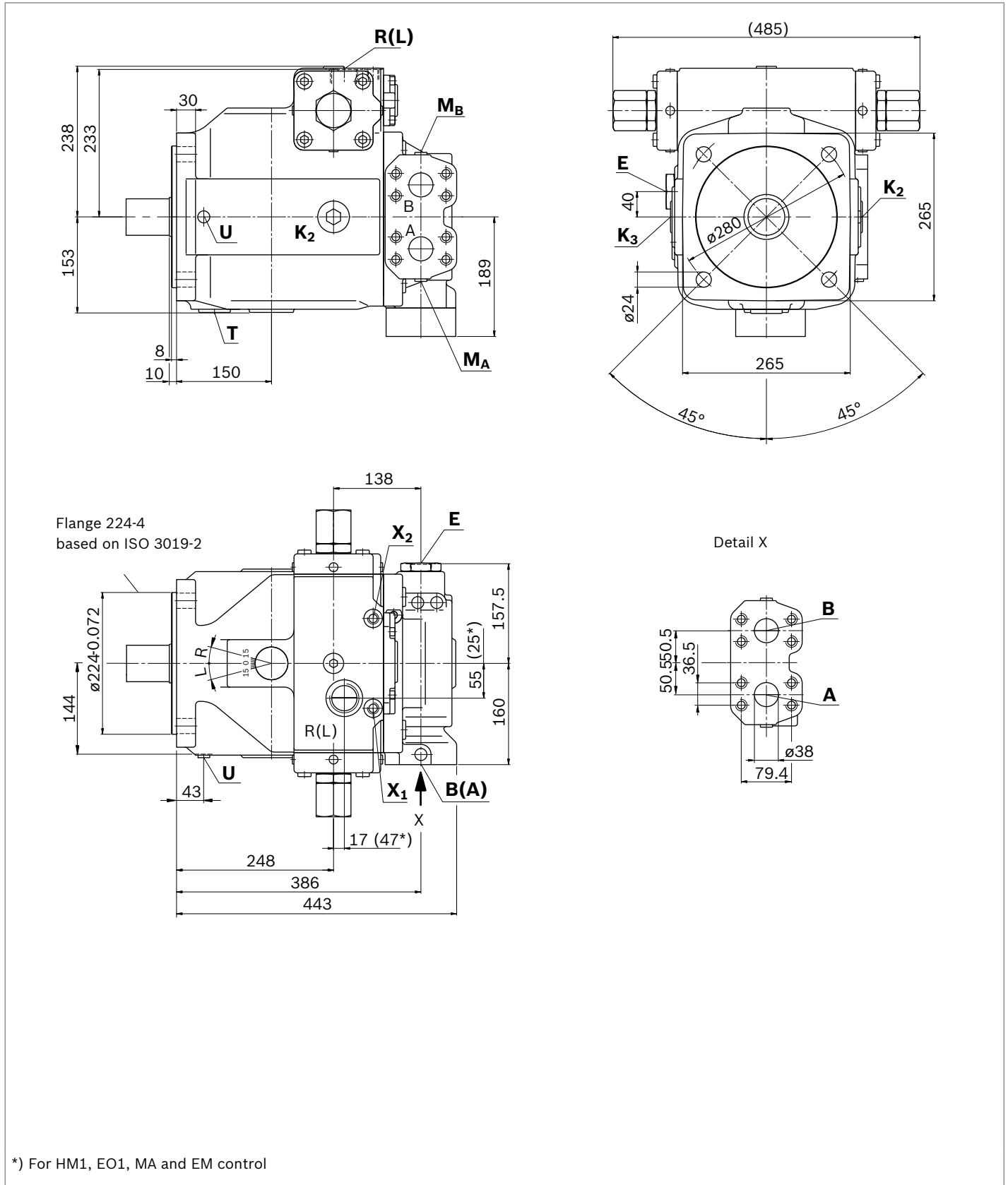

▼ **Splined shaft DIN 5480**

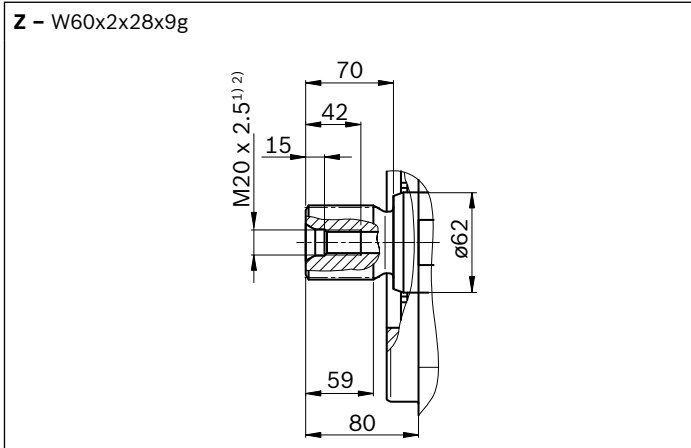

▼ **Parallel keyed shaft DIN 6885**

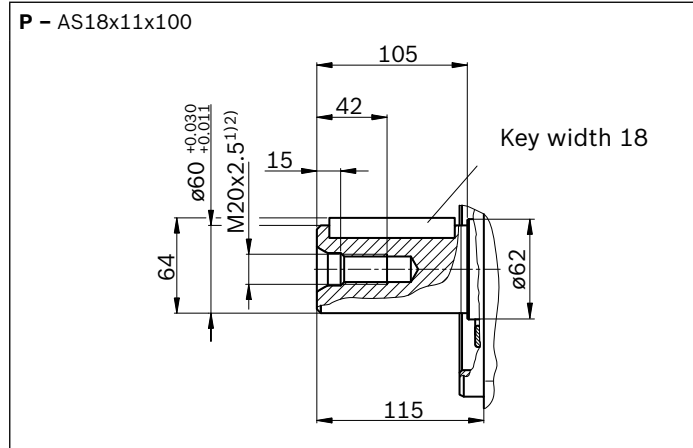

Ports		Standard	Size ²⁾	$p_{max\ abs}$ [bar] ³⁾	State ⁷⁾
A, B	Working port (high-pressure series) Fastening thread	SAE J518 ⁴⁾ DIN 13	1 1/2 in M16 × 2; 21 deep	400	O
M_A, M_B	Measuring working pressure A/B	DIN 3852	M14 × 1.5; 12 deep	400	X
T	Fluid drain	DIN 3852 ⁵⁾	M42 × 2; 20 deep	4	X ⁶⁾
E	Boost pressure supply	DIN 3852	M33 × 2; 18 deep	50	O
X₁, X₂	Control pressure (for HM1)	DIN 3852	M14 × 1.5; 12 deep	100	O
X₁, X₂	Control pressure (for HM2)	DIN 3852	M18 × 1.5; 12 deep	350	O
K₂, K₃	Filling – air bleeding, return flow (drain port)	DIN 3852 ⁵⁾	M42 × 2; 20 deep	4	X ⁶⁾
R(L)	Filling – air bleeding, return flow (drain port)	DIN 3852 ⁵⁾	M42 × 2; 20 deep	4	O ⁶⁾
U	Bearing flushing	DIN 3852 ⁵⁾	M14 × 1.5; 12 deep	7	X

1) Center bore according to DIN 332 (thread according to DIN 13)
 2) Observe the instructions in the instruction manual concerning the maximum tightening torques.
 3) Depending on the application, momentary pressure peaks can occur. Keep this in mind when selecting measuring devices and fittings.
 4) Metric fastening thread is a deviation from standard.

5) The countersink can be deeper than as specified in the standard.
 6) Depending on the installation position, T₁, K₂, K₃ or R(L) must be connected (see also installation instructions on pages 50 and 52).
 7) O = Must be connected (plugged when delivered)
 X = Plugged (in normal operation)

Dimensions, size 355

Example: **HM. – Hydraulic control, control volume dependent**, for additional dimensions, see data sheets for the controls

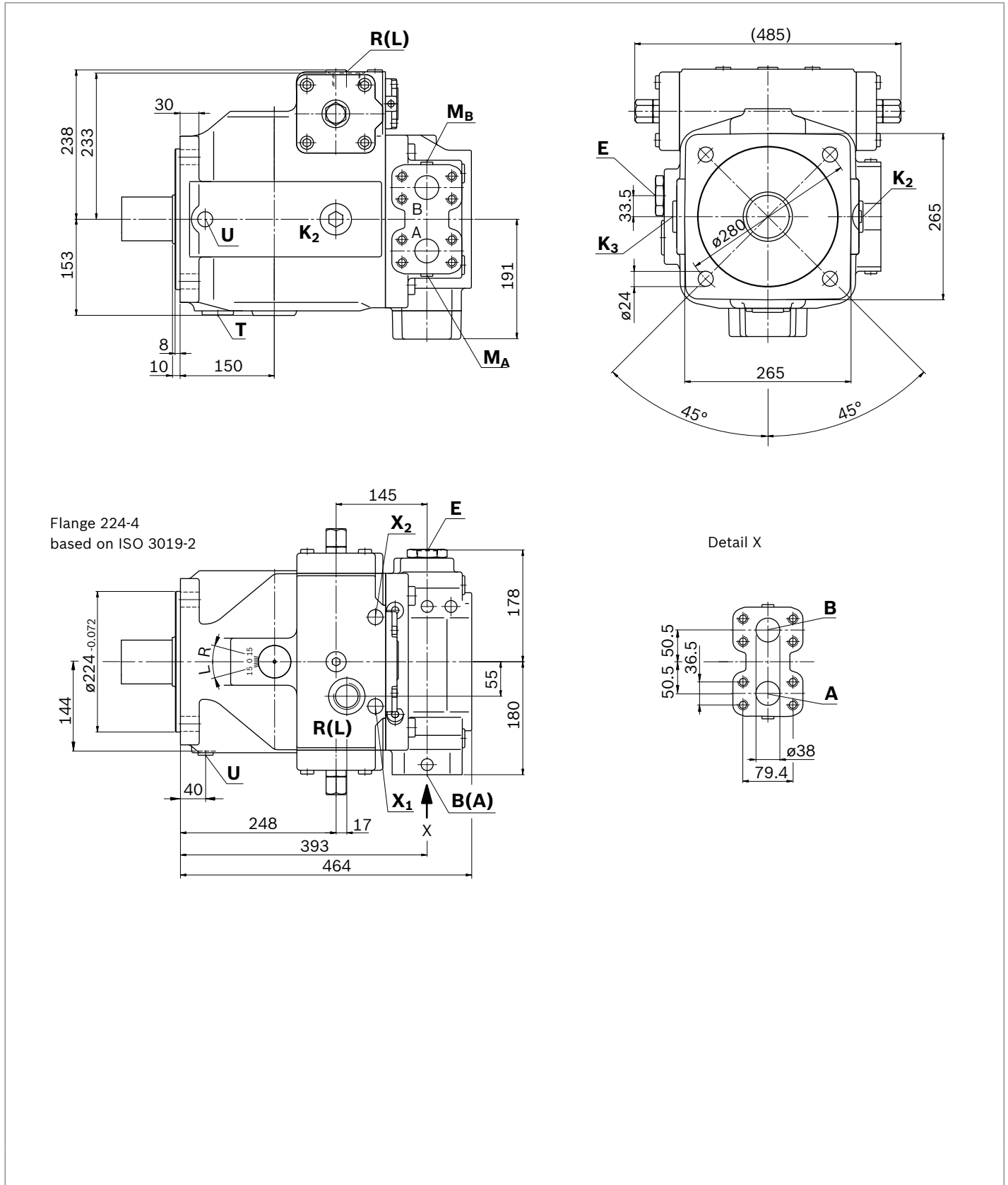

▼ Splined shaft DIN 5480

Z – W70x3x22x9g

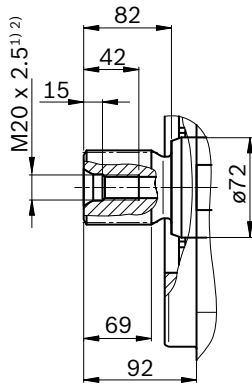

▼ Parallel keyed shaft DIN 6885

P – AS20x12x100

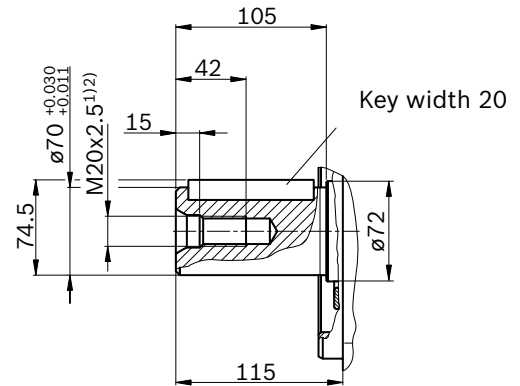

Ports		Standard	Size ²⁾	$p_{\max \text{ abs}}$ [bar] ³⁾	State ⁷⁾
A, B	Working port (high-pressure series) Fastening thread	SAE J518 ⁴⁾ DIN 13	1 1/2 in M16 × 2; 21 deep	400	O
M_A, M_B	Measuring working pressure A/B	DIN 3852	M14 × 1.5; 12 deep	400	X
T	Fluid drain	DIN 3852 ⁵⁾	M42 × 2; 20 deep	4	X ⁶⁾
E	Boost pressure supply	DIN 3852	M33 × 2; 18 deep	50	O
X₁, X₂	Control pressure (for HM2)	DIN 3852	M18 × 1.5; 12 deep	350	O
K₂, K₃	Filling – air bleeding, return flow (drain port)	DIN 3852 ⁵⁾	M42 × 2; 20 deep	4	X ⁶⁾
R(L)	Filling – air bleeding, return flow (drain port)	DIN 3852 ⁵⁾	M42 × 2; 20 deep	4	O ⁶⁾
U	Bearing flushing	DIN 3852 ⁵⁾	M14 × 1.5; 12 deep	7	X

- Center bore according to DIN 332 (thread according to DIN 13)
- Observe the instructions in the instruction manual concerning the maximum tightening torques.
- Depending on the application, momentary pressure peaks can occur. Keep this in mind when selecting measuring devices and fittings.
- Metric fastening thread is a deviation from standard.

- The countersink can be deeper than as specified in the standard.
- Depending on the installation position, T₁, K₂, K₃ or R(L) must be connected (see also installation instructions on pages 50 and 52).
- O = Must be connected (plugged when delivered)
X = Plugged (in normal operation)

Dimensions, size 500

Example: **HM. – Hydraulic control, control volume dependent**, for additional dimensions, see data sheets for the controls

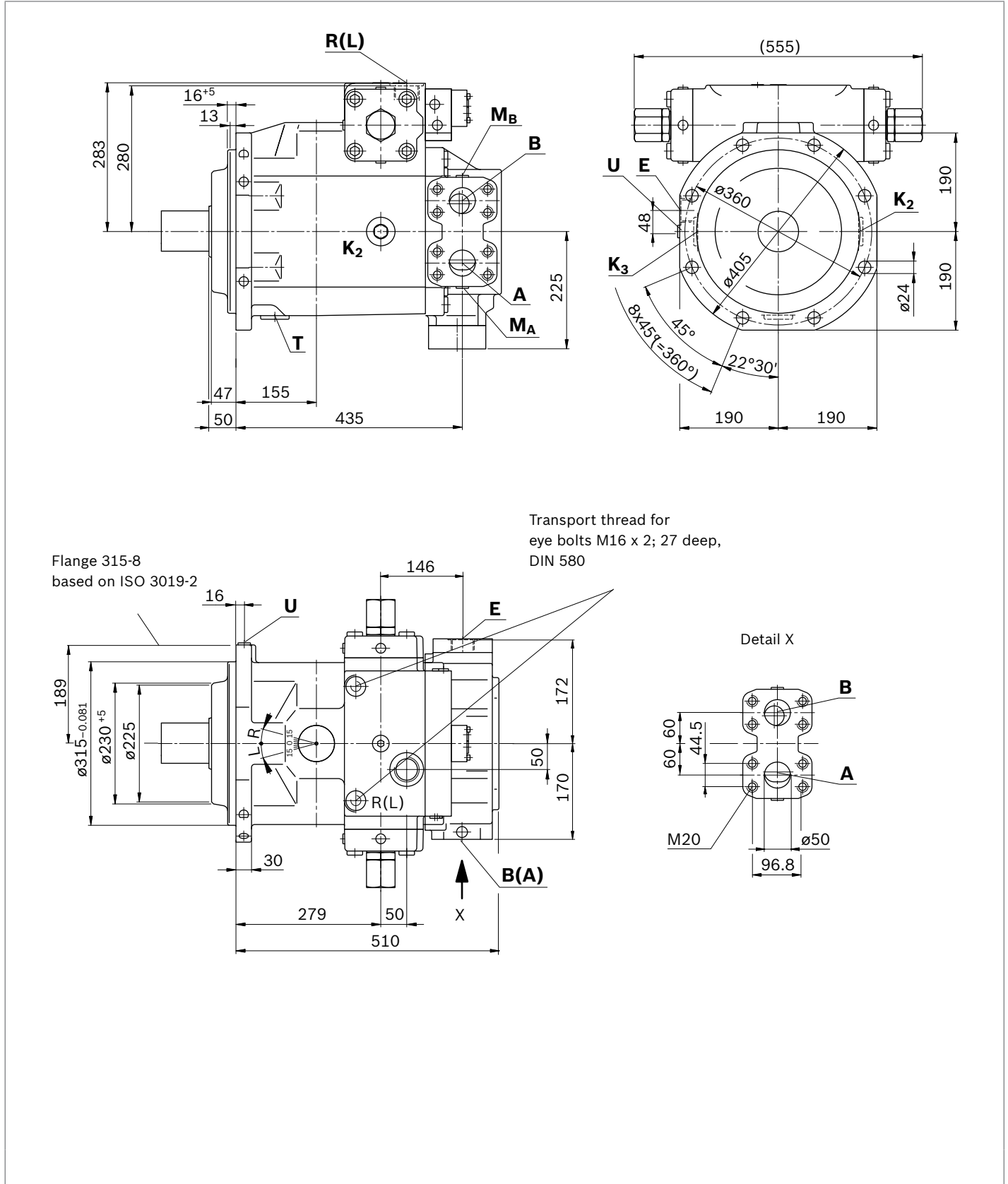

▼ Splined shaft DIN 5480

Z – W80x3x25x9g

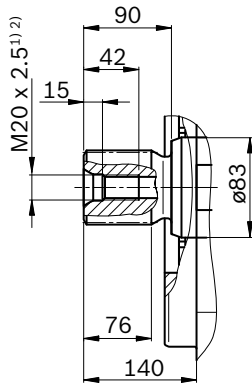

▼ Parallel keyed shaft DIN 6885

P – AS22x14x125

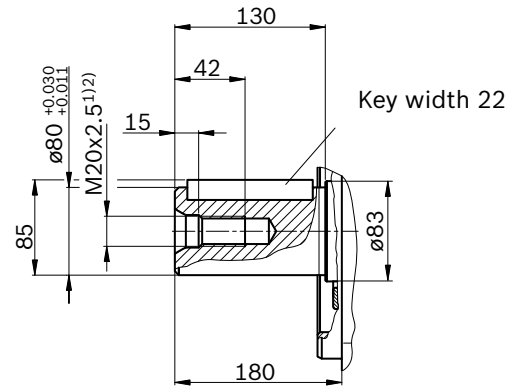

Ports		Standard	Size ²⁾	$p_{\max \text{ abs}}$ [bar] ³⁾	State ⁷⁾
A, B	Working port (high-pressure series) Fastening thread	SAE J518 ⁴⁾ DIN 13	2 in M20 × 2.5; 24 deep	400	O
M_A, M_B	Measuring working pressure A/B	DIN 3852	M18 × 1.5; 12 deep	400	X
T	Fluid drain	DIN 3852 ⁵⁾	M48 × 2; 20 deep	4	X ⁶⁾
E	Boost pressure supply	DIN 3852	M33 × 2; 18 deep	50	O
X₁, X₂	Control pressure (for HM2)	DIN 3852	M27 × 2; 16 deep	350	O
K₂, K₃	Filling – air bleeding, return flow (drain port)	DIN 3852 ⁵⁾	M48 × 2; 20 deep	4	X ⁶⁾
R(L)	Filling – air bleeding, return flow (drain port)	DIN 3852 ⁵⁾	M48 × 2; 20 deep	4	O ⁶⁾
U	Bearing flushing	DIN 3852 ⁵⁾	M18 × 1.5; 12 deep	7	X

- Center bore according to DIN 332 (thread according to DIN 13)
- Observe the instructions in the instruction manual concerning the maximum tightening torques.
- Depending on the application, momentary pressure peaks can occur. Keep this in mind when selecting measuring devices and fittings.
- Metric fastening thread is a deviation from standard.

- The countersink can be deeper than as specified in the standard.
- Depending on the installation position, T₁, K₂, K₃ or R(L) must be connected (see also installation instructions on pages 50 and 52).
- O = Must be connected (plugged when delivered)
X = Plugged (in normal operation)

▼ Splined shaft DIN 5480

Z – W90x3x28x9g

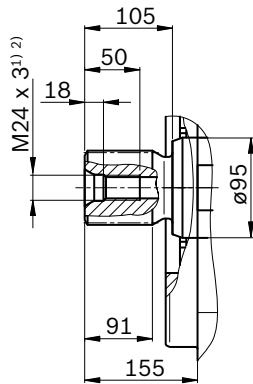

▼ Parallel keyed shaft DIN 6885

P – AS25x14x125

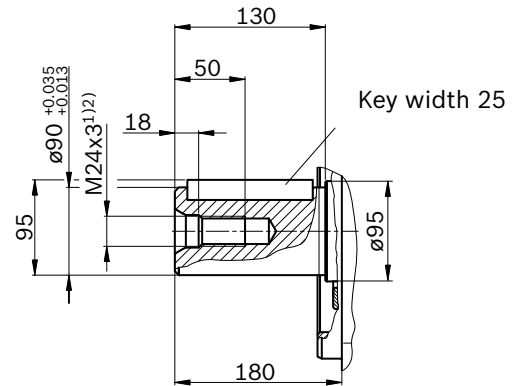

Ports		Standard	Size ²⁾	$p_{\max \text{ abs}}$ [bar] ³⁾	State ⁷⁾
A, B	Working port (high-pressure series) Fastening thread	SAE J518 ⁴⁾ DIN 13	2 in M20 × 2.5; 24 deep	400	O
M_A, M_B	Measuring working pressure A/B	DIN 3852	M18 × 1.5; 12 deep	400	X
T	Fluid drain	DIN 3852 ⁵⁾	M48 × 2; 20 deep	4	X ⁶⁾
E	Boost pressure supply	DIN 3852	M33 × 2; 18 deep	50	O
X₁, X₂	Control pressure (for HM2)	DIN 3852	M27 × 2; 16 deep	350	O
K₂, K₃	Filling – air bleeding, return flow (drain port)	DIN 3852 ⁵⁾	M48 × 2; 20 deep	4	X ⁶⁾
R(L)	Filling – air bleeding, return flow (drain port)	DIN 3852 ⁵⁾	M48 × 2; 20 deep	4	O ⁶⁾
U	Bearing flushing	DIN 3852 ⁵⁾	M18 × 1.5; 12 deep	7	X

- Center bore according to DIN 332 (thread according to DIN 13)
- Observe the instructions in the instruction manual concerning the maximum tightening torques.
- Depending on the application, momentary pressure peaks can occur. Keep this in mind when selecting measuring devices and fittings.
- Metric fastening thread is a deviation from standard.

- The countersink can be deeper than as specified in the standard.
- Depending on the installation position, T₁, K₂, K₃ or R(L) must be connected (see also installation instructions on pages 50 and 52).
- O = Must be connected (plugged when delivered)
X = Plugged (in normal operation)

Dimensions size 1000

Example: **HM. – Hydraulic control, control volume dependent**, for additional dimensions, see data sheets for the controls

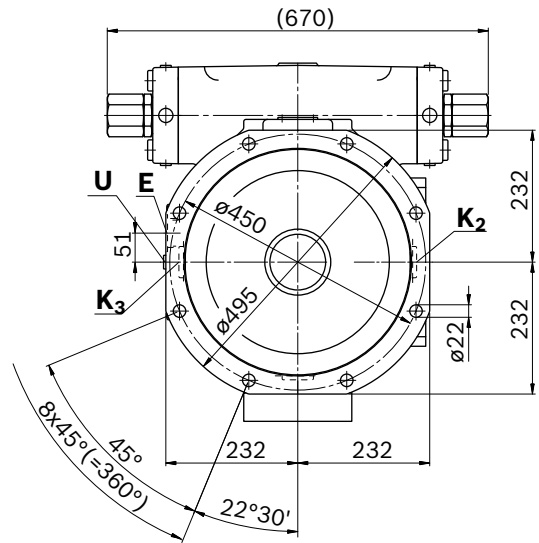
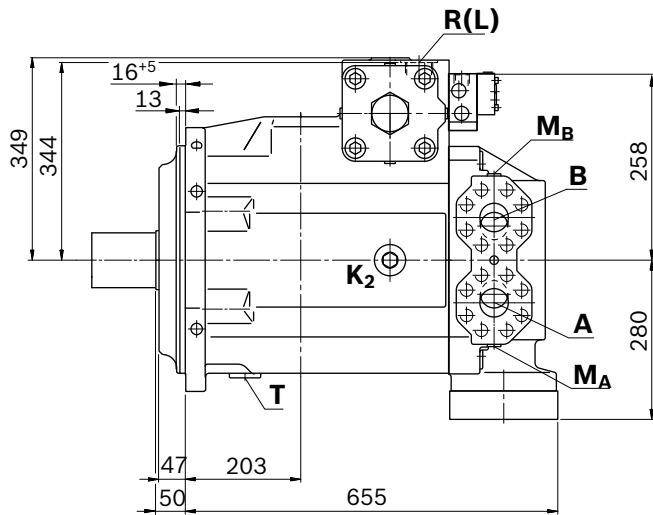

Flange 400-8
 based on ISO 3019-2

Transport thread for
 eye bolts M20 x 2.5; 30 deep,
 DIN 580

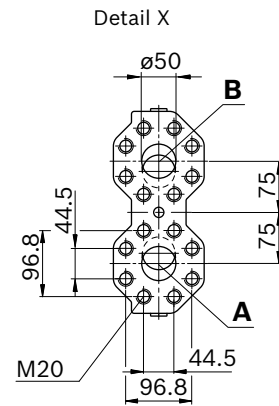
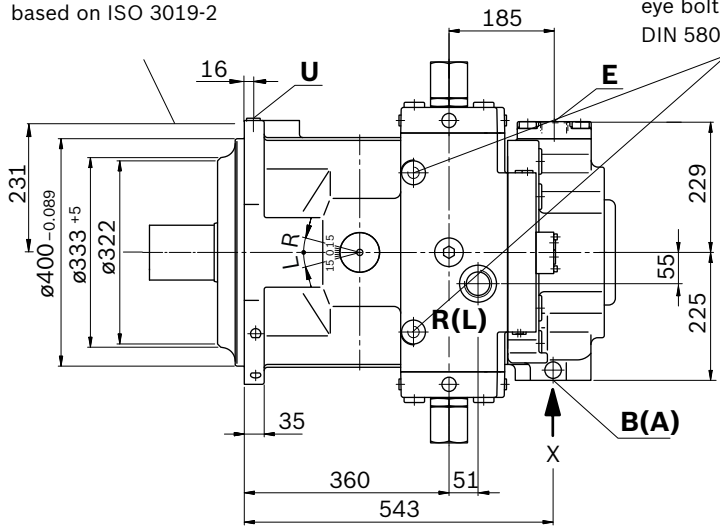

▼ Splined shaft DIN 5480

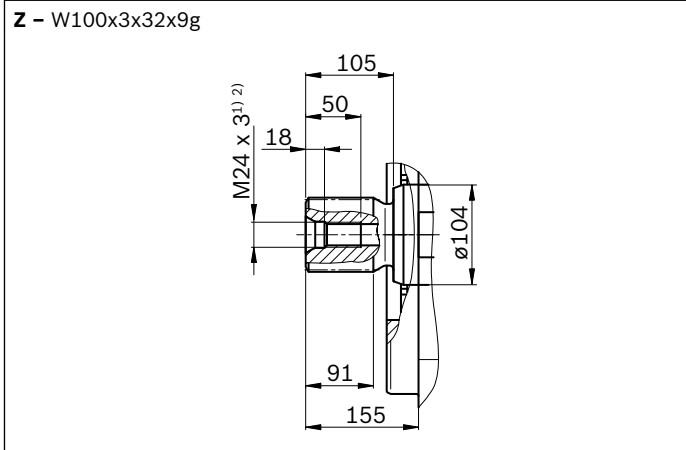

▼ Parallel keyed shaft DIN 6885

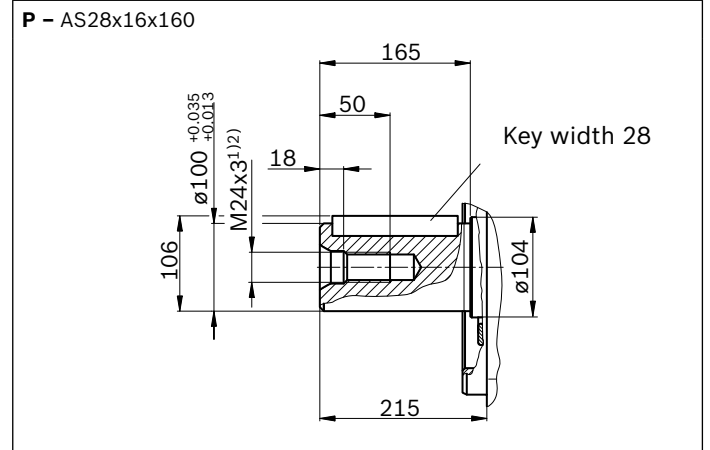

Ports		Standard	Size ²⁾	$p_{\max \text{ abs}}$ [bar] ³⁾	State ⁷⁾
A, B	Working port (high-pressure series) Fastening thread	SAE J518 ⁴⁾ DIN 13	2 in M20 × 2.5; 30 deep	400	O
M_A, M_B	Measuring working pressure A/B	DIN 3852	M18 × 1.5; 12 deep	400	X
T	Fluid drain	DIN 3852 ⁵⁾	M48 × 2; 20 deep	4	X ⁶⁾
E	Boost pressure supply	DIN 3852	M48 × 2; 20 deep	50	O
K₂, K₃	Filling – air bleeding, return flow (drain port)	DIN 3852 ⁵⁾	M48 × 2; 20 deep	4	X ⁶⁾
R(L)	Filling – air bleeding, return flow (drain port)	DIN 3852 ⁵⁾	M48 × 2; 20 deep	4	O ⁶⁾
U	Bearing flushing	DIN 3852 ⁵⁾	M18 × 1.5; 12 deep	7	X

- Center bore according to DIN 332 (thread according to DIN 13)
- Observe the instructions in the instruction manual concerning the maximum tightening torques.
- Depending on the application, momentary pressure peaks can occur. Keep this in mind when selecting measuring devices and fittings.
- Metric fastening thread is a deviation from standard.

- The countersink can be deeper than as specified in the standard.
- Depending on the installation position, T₁, K₂, K₃ or R(L) must be connected (see also installation instructions on pages 50 and 52).
- O = Must be connected (plugged when delivered)
X = Plugged (in normal operation)

Dimensions, through drives

Flange ISO 3019-2 (metric)		Hub for splined shaft ¹⁾	Availability over sizes									Code
Diameter	Attachment ²⁾	Diameter	40	71	125	180	250	355	500	750	1000	
125-4		N32 × 2 × 14 × 8H	●	●	●	●	●	○	●	○	○	K31
140-4		N40 × 2 × 18 × 8H	-	●	●	●	●	●	●	○	●	K33

● = Available ○ = On request

▼ 125-4

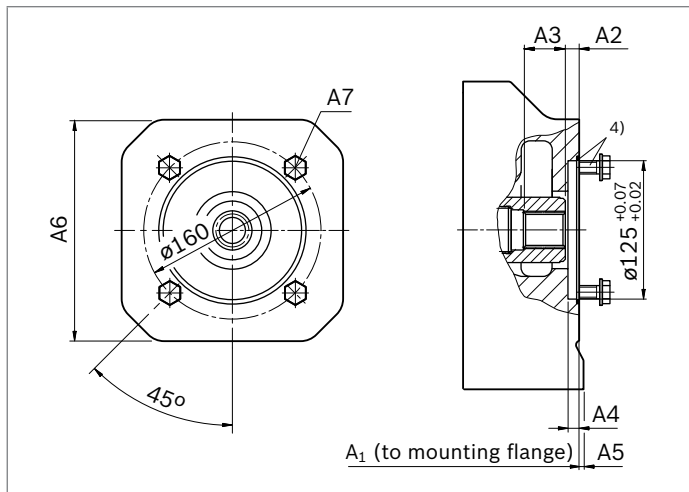

K31							
NG	A1	A2	A3	A4	A5	A6	A7 ³⁾
40	288	12.5	41.4	9.5	-	-	M12; 25 deep
71	316	12.5	33.6	10	-	-	M12; 25 deep
125	373	12.5	42	9.5	-	-	M12; 25 deep
180	397	12.5	42	9.5	-	-	M12; 25 deep
250	431	12.5	37.9	10	10	200	M12; 18 deep
500	505	12.5	38.5	10	-	-	M12; 18 deep

▼ 140-4

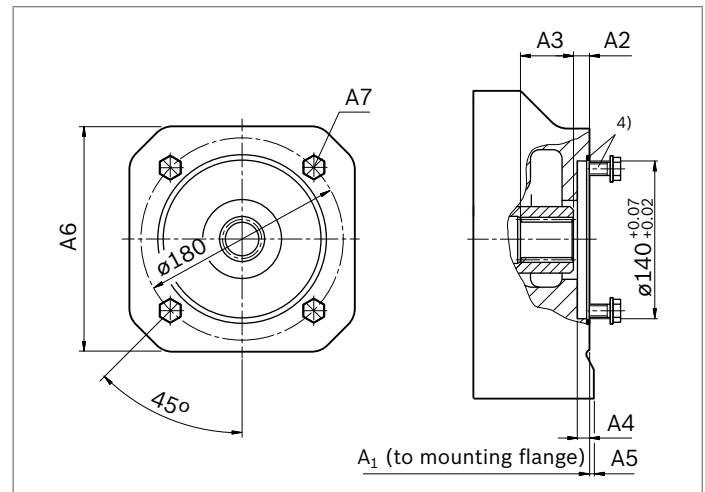

K33							
NG	A1	A2	A3	A4	A5	A6	A7 ³⁾
71	316	11.5	44	9	-	-	M12; 25 deep
125	373	12.5	50	9.5	-	-	M12; 25 deep
180	397	12.5	43.8	9.5	-	-	M12; 25 deep
250	431	12.5	49	10	10	200	M12; 18 deep
355	460	12.5	49	10	-	-	M12; 18 deep
500	505	12.5	44	10	-	-	M12; 18 deep
1000	628	12.5	64.5	10	27	280	M12; 18 deep

1) According to DIN 5480

2) Mounting holes pattern viewed on through drive with control at top

3) Thread according to DIN 13, observe the instructions in the instruction manual for the maximum tightening torques.

4) O-ring and mounting bolts are included in the scope of delivery

Dimensions, through drives

Flange ISO 3019-2 (metric)		Hub for splined shaft ¹⁾	Availability over sizes									Code
Diameter	Attachment ²⁾	Diameter	40	71	125	180	250	355	500	750	1000	
160-4		N50 × 2 × 24 × 8H	-	-	●	●	●	●	●	○	●	K34
224-4		N60 × 2 × 28 × 8H	-	-	-	-	●	●	●	●	●	K35

● = Available ○ = On request

▼ 160-4

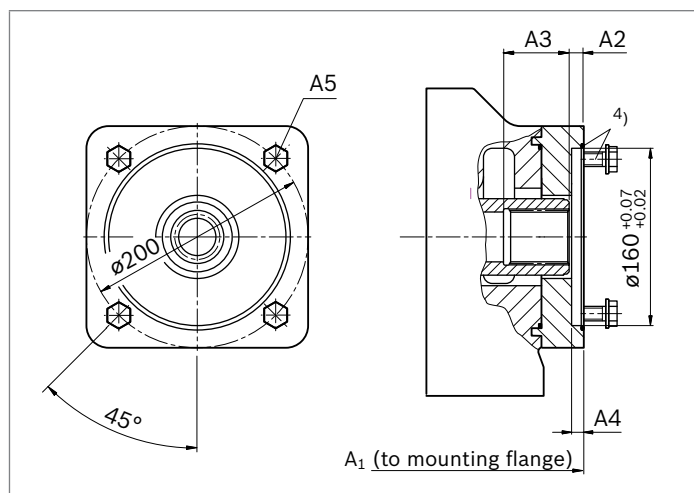

K34					
NG	A1	A2	A3	A4	A5 ³⁾
125	379	12.5	58	10	M16; 30 deep
180	403	12.5	58	10	M16; 30 deep
250	469	12.5	60	10	M16; 32 deep
355	498	12.5	60	10	M16; 32 deep
500	505	13.5	55	10	M16; 24 deep
1000	628	12.5	55	10	M16; 24 deep

▼ 224-4

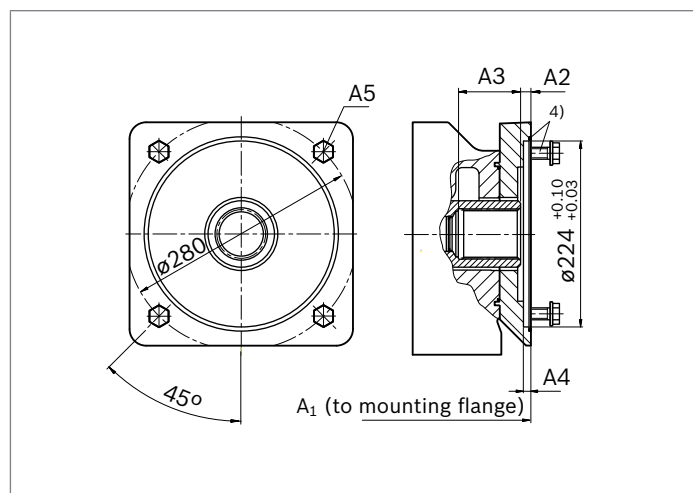

K35					
NG	A1	A2	A3	A4	A5 ³⁾
250	469	12.5	75	9	M20; 36 deep
355	498	12.5	75	9	M20; 36 deep
500	541	12.5	74	9	M20; 36 deep
750	591	12.5	74	9	M20; 36 deep
1000	664	12.5	69.5	9	M20; 36 deep

1) According to DIN 5480

2) Mounting holes pattern viewed on through drive with control at top

3) Thread according to DIN 13, observe the instructions in the instruction manual for the maximum tightening torques.

4) O-ring and mounting bolts are included in the scope of delivery

Dimensions, through drives

Flange ISO 3019-2 (metric)		Hub for splined shaft ¹⁾	Availability over sizes									Code
Diameter	Attachment ²⁾	Diameter	40	71	125	180	250	355	500	750	1000	
224-4		N70 × 3 × 22 × 8H	-	-	-	-	-	●	●	○	●	K77
315-8		N80 × 3 × 25 × 8H	-	-	-	-	-	-	●	○	●	K43

● = Available ○ = On request

▼ 224-4

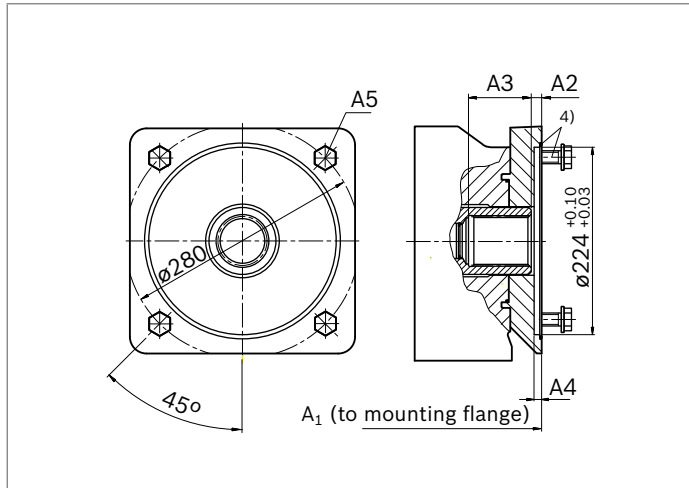

K77					
NG	A1	A2	A3	A4	A5 ³⁾
355	498	12.5	82	9	M20; 36 deep
500	541	12.5	82	9	M20; 36 deep
1000	664	12.5	82	9	M20; 36 deep

▼ 315-8

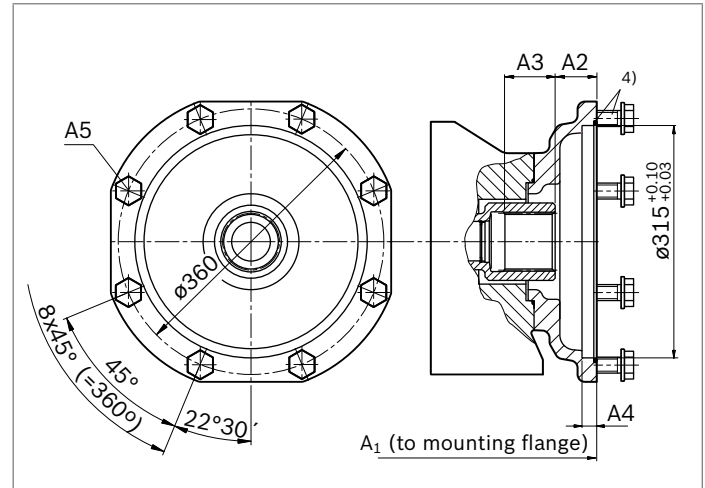

K43					
NG	A1	A2	A3	A4	A5 ³⁾
500	590	53.5	71.9	19	M20; 26 deep
1000	713	53.5	71	19	M20; 26 deep

1) According to DIN 5480

2) Mounting holes pattern viewed on through drive with control at top

3) Thread according to DIN 13, observe the instructions in the instruction manual for the maximum tightening torques.

4) O-ring and mounting bolts are included in the scope of delivery

Dimensions, through drives

Flange ISO 3019-2 (metric)		Hub for splined shaft ¹⁾	Availability over sizes									Code
Diameter	Attachment ²⁾	Diameter	40	71	125	180	250	355	500	750	1000	
400-8		N90 × 3 × 28 × 8H	-	-	-	-	-	-	-	●	●	K76
400-8		N100 × 3 × 32 × 8H	-	-	-	-	-	-	-	-	●	K88

● = Available ○ = On request

▼ 400-8

▼ 400-8

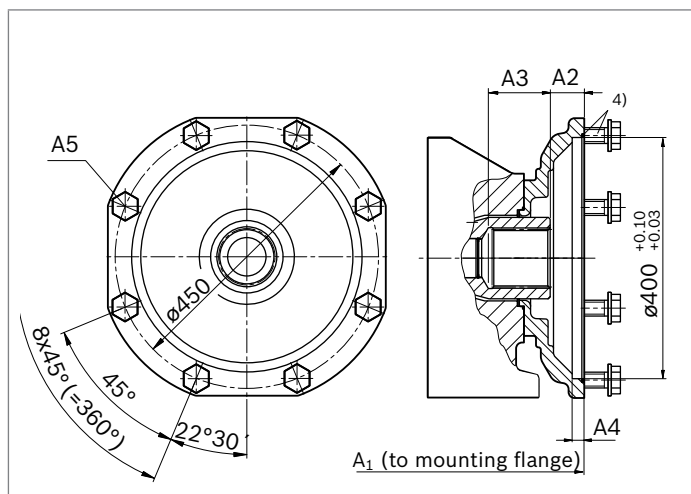
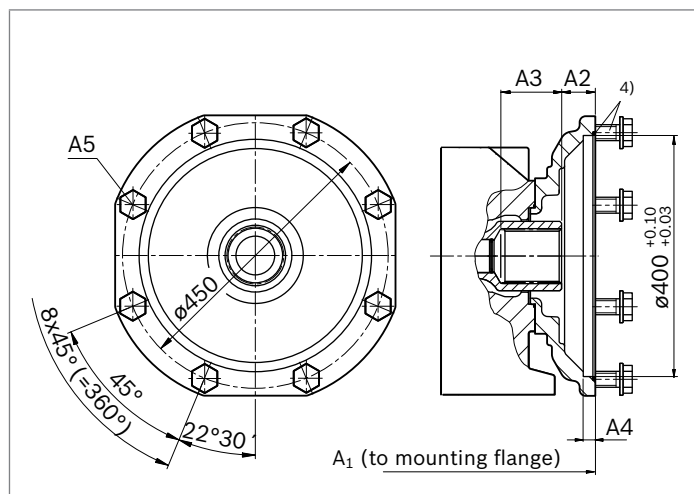

K76						
NG	A1	A2	A3	A4	A5 ³⁾	
750	655	53	104	19	M20; 26 deep	
1000	728	53	97	19	M20; 26 deep	

K88						
NG	A1	A2	A3	A4	A5 ³⁾	
1000	728	53	99	19	M20; 26 deep	

1) According to DIN 5480

2) Mounting holes pattern viewed on through drive with control at top

3) Thread according to DIN 13, observe the instructions in the instruction manual for the maximum tightening torques.

4) O-ring and mounting bolts are included in the scope of delivery

Dimensions, through drives

Flange ISO 3019-2 (metric)		Hub for splined shaft ¹⁾		Availability over sizes									Code	
Diameter	Attachment ²⁾	Diameter		40	71	125	180	250	355	500	750	1000		
80-2		3/4in	11T 16/32DP	○	●	●	○	○	○	○	○	○	○	KB2

▼ 80-2

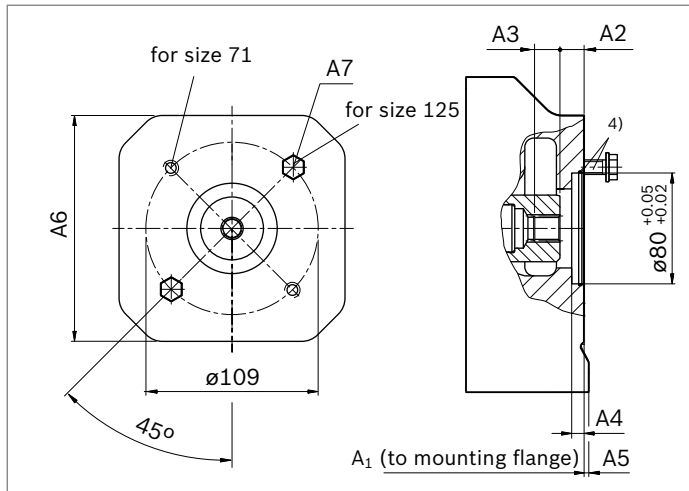

KB2							
NG	A1	A2	A3	A4	A5	A6	A7 ³⁾
71	291	21.5	19	10	15	140	M10; 15 deep
125	379	24.2	20.5	10	-	-	M10; 12 deep

Dimensions, through drives

Flange ISO 3019-2 (metric)		Hub for splined shaft ¹⁾		Availability over sizes									Code
Diameter	Attachment ²⁾	Diameter		40	71	125	180	250	355	500	750	1000	
100-2		7/8in	13T 16/32DP	●	●	●	●	●	●	○	○	○	KB3
100-2		1in	15T 16/32DP	○	●	●	●	●	○	○	○	○	KB4

● = Available ○ = On request

▼ 100-2

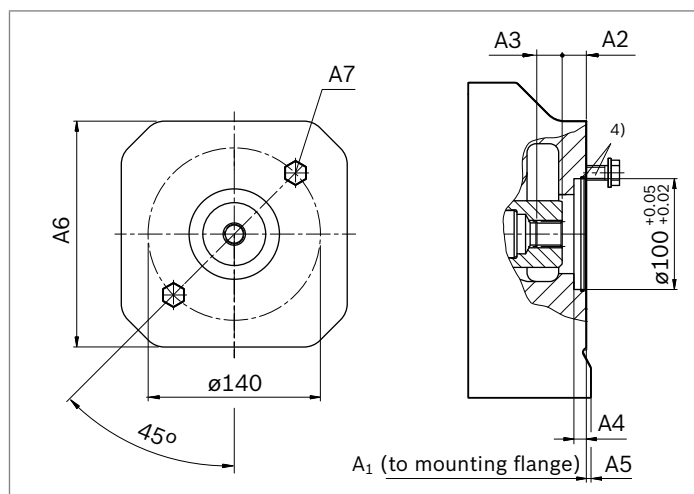

KB3							
NG	A1	A2	A3	A4	A5	A6	A7 ³⁾
40	290	20.4	23	10	-	-	M12; 18 deep
71	316	20.4	23	9	-	-	M12; 18 deep
125	378	20.3	24.5	10	-	-	M12; 24 deep
180	371	20.5	23	10	-	-	M12; 15 deep
250	431	20.5	23	10	10	200	M12; 18 deep
355	460	20.5	23	10	-	-	M12; 18 deep

▼ 100-2

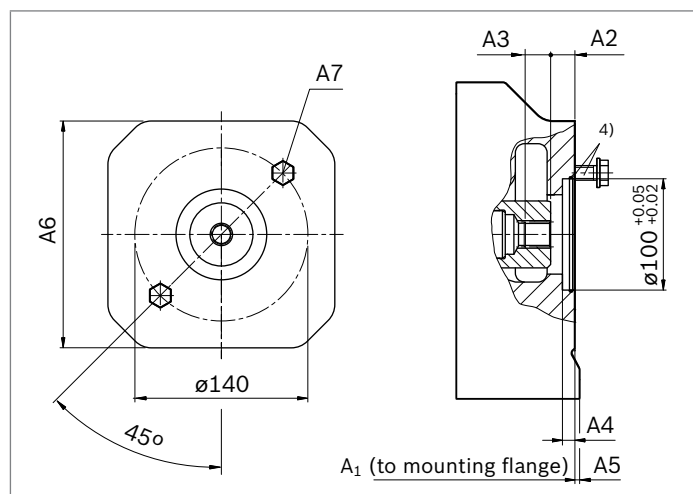

KB4							
NG	A1	A2	A3	A4	A5	A6	A7 ³⁾
71	316	20.8	27.5	8	-	-	M12; 24 deep
125	378	22.2	29	10	-	-	M12; 24 deep
180	371	21.8	27.9	10	-	-	M12; 15 deep
250	431	20.9	27.5	10	10	200	M12; 18 deep

1) According to ANSI B92.1a, 30° pressure angle, flat root, side fit, tolerance class 5
 2) Mounting holes pattern viewed on through drive with control at top
 3) Thread according to DIN 13, observe the instructions in the instruction manual for the maximum tightening torques.

4) O-ring and mounting bolts are included in the scope of delivery

Dimensions, through drives

Flange ISO 3019-2 (metric)		Hub for splined shaft ¹⁾	Availability over sizes										Code
Diameter	Attachment ²⁾	Diameter	40	71	125	180	250	355	500	750	1000		
125-2		1 1/4in 14T 12/24DP	-	●	●	●	●	●	●	○	○	KB5	
125-2		1 1/2 in 17T 12/24DP	-	-	●	●	●	●	●	●	○	KB6	

● = Available ○ = On request

▼ 125-2

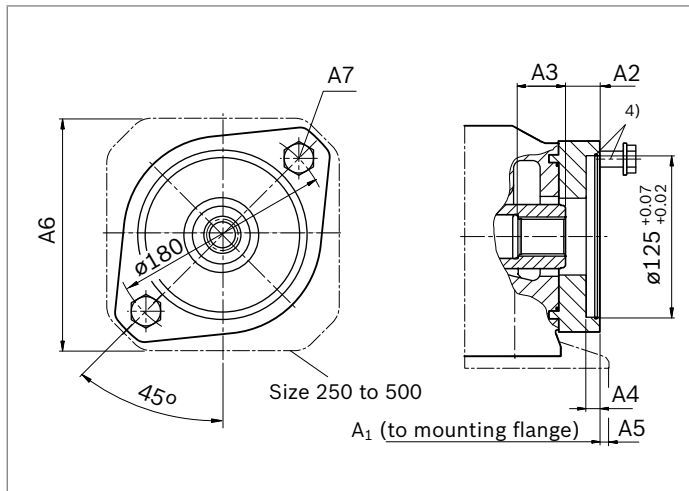

KB5	NG	A1	A2	A3	A4	A5	A6	A7 ³⁾
	71	321	23.1	38.1	10	-	-	M16; 29 deep
	125	378	23.7	38.1	9.5	-	-	M16; 24 deep
	180	402	23.7	38.1	9.5	-	-	M16; 24 deep
	250	431	22	36.1	10	10	200	M16; 20 deep
	355	460	22	36.1	10	-	-	M16; 24 deep
	500	505	19.3	40.4	10	-	-	M16; 24 deep

▼ 125-2

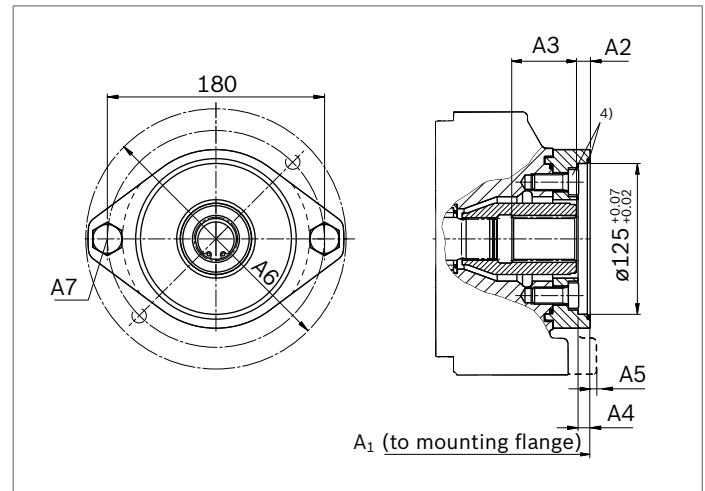

KB6	NG	A1	A2	A3	A4	A5	A6	A7 ³⁾
	125	378	11.4	54	9.5	-	-	M16; 24 deep
	180	402	11.4	54	9.5	-	-	M16; 24 deep
	250	451	10.4	55	10	-	-	M1620 deep
	355	480	10.4	55	10	-	-	M16; 20 deep
	500	505	10.3	56	10	-	-	M16; 24 deep
	750	555	10.3	56	10	23	250	M16; 24 deep

1) According to ANSI B92.1a, 30° pressure angle, flat root, side fit, tolerance class 5

2) Mounting holes pattern viewed on through drive with control at top

3) Thread according to DIN 13, observe the instructions in the instruction manual for the maximum tightening torques.

4) O-ring and mounting bolts are included in the scope of delivery

Dimensions, through drives

Flange ISO 3019-2 (metric)		Hub for splined shaft ¹⁾		Availability over sizes								Code	
Diameter	Attachment ²⁾	Diameter		40	71	125	180	250	355	500	750	1000	
180-4		1 3/4in 13T 8/16DP		-	-	•	•	•	•	•	•	○	KB7

• = Available ○ = On request

▼ **180-4**

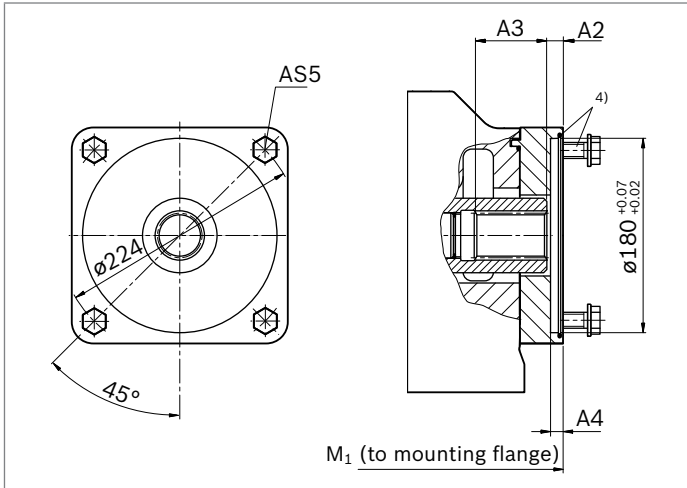

KB7					
NG	A1	A2	A3	A4	A5 ³⁾
125	395	10.5	45	10	M16; 30 deep
180	419	10.5	45	10	M16; 30 deep
250	469	10.8	67	10	M16; 32 deep
355	498	10.8	67	10	M16; 32 deep
500	530	10.4	63	10	M16; 25 deep
750	580	10.4	63	10	M16; 25 deep

1) According to ANSI B92.1a, 30° pressure angle, flat root, side fit, tolerance class 5

2) Mounting holes pattern viewed on through drive with control at top

3) Thread according to DIN 13, observe the instructions in the instruction manual for the maximum tightening torques.

4) O-ring and mounting bolts are included in the scope of delivery

Dimensions, through drives

Flange ISO 3019-1 (SAE J744)		Hub for splined shaft ¹⁾		Availability over sizes									Code
Diameter	Attachment ²⁾	Diameter		40	71	125	180	250	355	500	750	1000	
82-2 (A)		5/8in	9T 16/32DP	●	●	●	●	●	●	●	●	○	K01
82-2 (A-B)		3/4in	11T 16/32DP	○	○	○	●	○	●	○	○	○	K52

● = Available ○ = On request

▼ 82-2

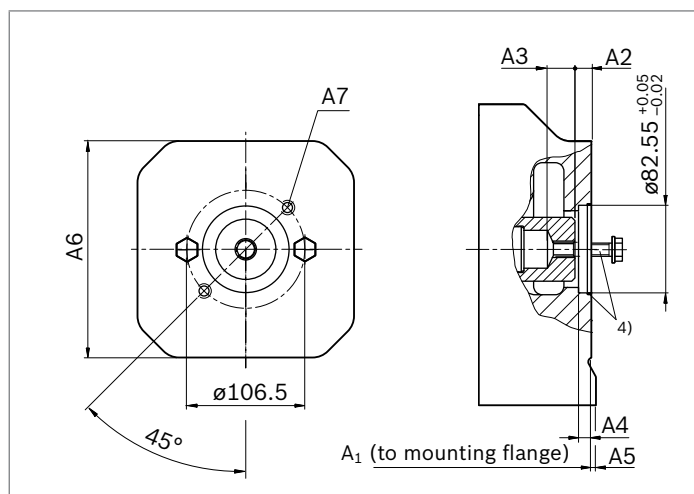

K01 (16-4 (A))							
NG	A1	A2	A3	A4	A5	A6	A7 ³⁾
40	263	10.5	25.8	10	18	130	M10; 15 deep
71	291	10.5	25.4	10	15	140	M10; 15 deep
125	347	10.3	28	10	13	150	M10; 15 deep
180	371	10.3	28	10	–	–	M10; 15 deep
250	431	10.5	30	10	10	200	M10; 15 deep
355	460	10.5	30	10	–	–	M10; 15 deep
500	505	10.3	33	10	–	–	M10; 15 deep
750	555	10.3	33	10	–	–	M10; 15 deep

▼ 82-2

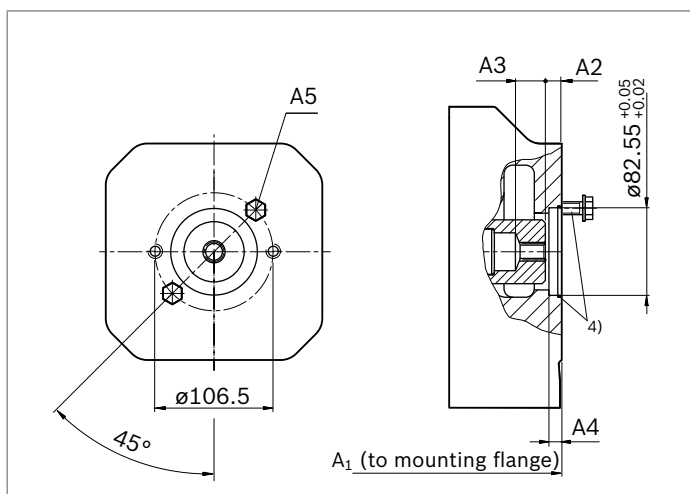

K52 (19-4 (A-B))					
NG	A1	A2	A3	A4	A5 ³⁾
180	371	21.4	19.1	10	M10; 15 deep
355	460	21.4	19.1	10	M10; 15 deep

1) According to ANSI B92.1a, 30° pressure angle, flat root, side fit, tolerance class 5

2) Mounting holes pattern viewed on through drive with control at top

3) Thread according to DIN 13, observe the instructions in the instruction manual for the maximum tightening torques.

4) O-ring and mounting bolts are included in the scope of delivery

Dimensions, through drives

Flange ISO 3019-1 (SAE J744)		Hub for splined shaft ¹⁾		Availability over sizes								Code	
Diameter	Attachment ²⁾	Diameter		40	71	125	180	250	355	500	750	1000	
101-2 (B)		7/8in 13T 16/32DP		●	●	●	●	●	●	●	●	○	K68
101-2 (B-B)		1in 15T 16/32DP		●	●	●	●	●	●	●	○	○	K04

● = Available ○ = On request

▼ 101-2

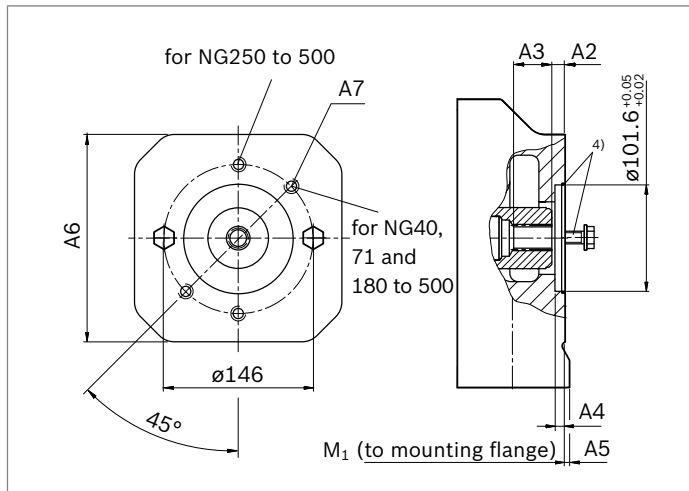

K68 (22-4 (B))							
NG	A1	A2	A3	A4	A5	A6	A7 ³⁾
40	290	20.4	23	10	-	-	M12; 18 deep
71	322	20.5	23	10	-	-	M12; 30 deep
125	347	20.5	23	10	16	150	M12; 15 deep
180	371	20.5	23	10	-	-	M12; 16 deep
250	431	20.5	23	10	10	200	M12; 18 deep
355	460	20.5	23	10	-	-	M12; 18 deep
500	505	19.5	25	10	-	-	M12; 18 deep
750	555	19.5	25	10	-	-	M12; 18 deep

▼ 101-2

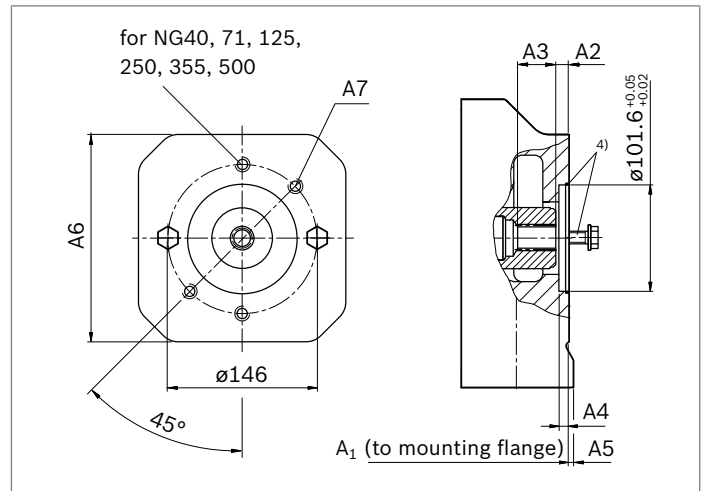

K04 (25-4 (B-B))							
NG	A1	A2	A3	A4	A5	A6	A7 ³⁾
40	290	20.8	27.5	10	-	-	M12; 20 deep
71	322	20	29.4	10	-	-	M12; 30 deep
125	379	23.7	29	10	-	-	M12; 30 deep
180	371	21.8	27.9	10	-	-	M12; 16 deep
250	431	20.9	27.5	10	10	200	M12; 18 deep
355	460	20.9	27.5	10	-	-	M12; 18 deep
500	505	20.4	28.9	10	-	-	M12; 18 deep

1) According to ANSI B92.1a, 30° pressure angle, flat root, side fit, tolerance class 5
 2) Mounting holes pattern viewed on through drive with control at top
 3) Thread according to DIN 13, observe the instructions in the instruction manual for the maximum tightening torques.

4) O-ring and mounting bolts are included in the scope of delivery

Dimensions, through drives

Flange ISO 3019-1 (SAE J744)		Hub for splined shaft ¹⁾	Availability over sizes										Code
Diameter	Attachment ²⁾	Diameter	40	71	125	180	250	355	500	750	1000		
127-2 (C)		1 1/4in 14T 12/24DP	-	•	•	•	•	•	•	•	•	K07	
127-2 (C-C)		1 1/2 in 17T 12/24DP	-	-	•	•	•	•	•	•	•	K24	

• = Available ◦ = On request

▼ 127-2

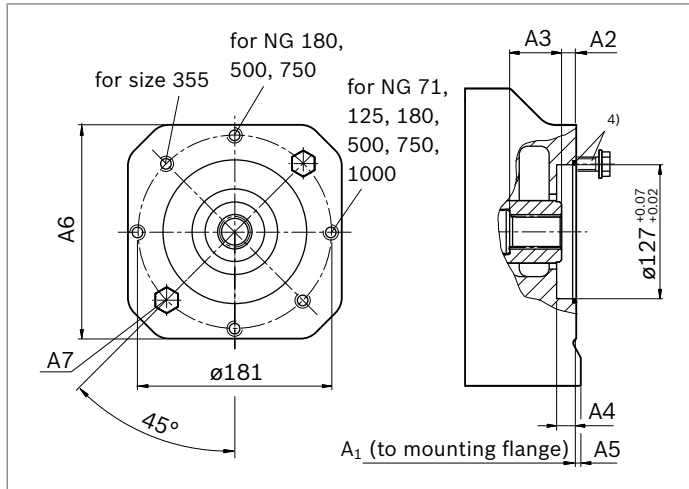

K07 (32-4 (C))							
NG	A1	A2	A3	A4	A5	A6	A7 ³⁾
71	321	23	38	13	-	-	M16; 30 deep
125	377	22.7	37.5	13	-	-	M16; 28 deep
180	401	22.7	37.5	13	-	-	M16; 28 deep
250	431	22	36	13	10	200	M16; 20 deep
355	460	22	36	13	-	-	M16; 24 deep
500	505	19.3	40.4	13	-	-	M16; 24 deep
750	555	19.3	40.4	13	23	250	M16; 24 deep
1000	628	10.4	54.6	13	25	280	M16; 32 deep

▼ 127-2

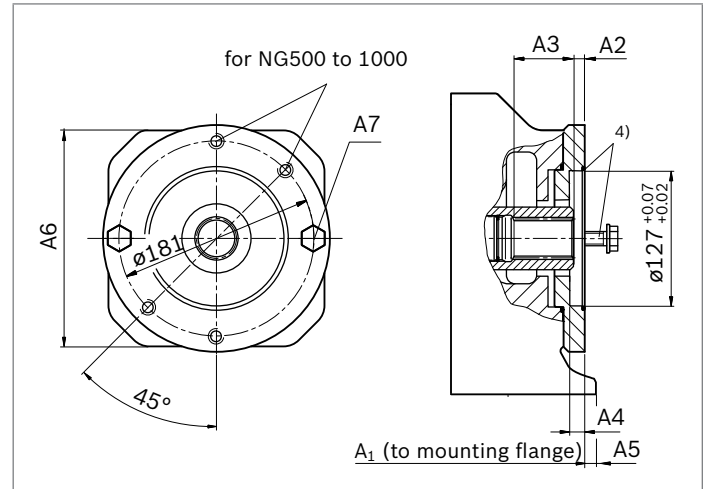

K24 (38-4 (C-C))							
NG	A1	A2	A3	A4	A5	A6	A7 ³⁾
125	377	10.4	54	13	-	-	M16; 28 deep
180	401	10.4	54	13	-	-	M16; 28 deep
250	451	10.4	57.6	13	-	-	M16; 20 deep
355	480	10.4	57.6	13	-	-	M16; 20 deep
500	505	10.3	56.7	13	-	-	M16; 24 deep
750	555	10.3	56.7	13	23	250	M16; 24 deep
1000	628	10.4	56.6	13	25	280	M16; 32 deep

1) According to ANSI B92.1a, 30° pressure angle, flat root, side fit, tolerance class 5

2) Mounting holes pattern viewed on through drive with control at top

3) Thread according to DIN 13, observe the instructions in the instruction manual for the maximum tightening torques.

4) O-ring and mounting bolts are included in the scope of delivery

Dimensions, through drives

Flange ISO 3019-1 (SAE J744)	Attachment ²⁾	Hub for splined shaft ¹⁾	Availability over sizes								Code	
			Diameter	40	71	125	180	250	355	500		750
152-4 (B)		1 3/4in 13T 8/16DP	-	-	•	•	•	•	•	•	○	K17

• = Available ○ = On request

▼ **152-4**

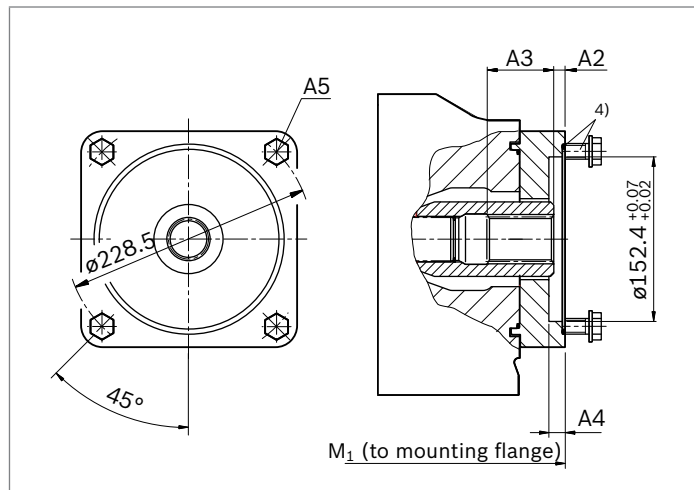

K17 (44-4 (D))					
NG	A1	A2	A3	A4	A5 ³⁾
125	382	10.4	62	13	M16; 30 deep
180	406	10.4	62	13	M16; 30 deep
250	473	10.4	62	13	M16; 32 deep
355	502	10.4	62	13	M16; 32 deep
500	530	10.4	63.6	13	M16; 25 deep
750	580	10.4	63.6	13	M16; 25 deep

1) According to ANSI B92.1a, 30° pressure angle, flat root, side fit, tolerance class 5
 2) Mounting holes pattern viewed on through drive with control at top
 3) Thread according to DIN 13, observe the instructions in the instruction manual for the maximum tightening torques.

4) O-ring and mounting bolts are included in the scope of delivery

Overview of mounting options

Through drive ¹⁾			Mounting options – 2nd pump				
Flange ISO 3019-2 (metric)	Hub for splined shaft	Code	A4VSO A4VSG NG (shaft)	A4CSG NG (shaft)	A10V(S)O/3x NG (shaft)	A10V(S)O/5x NG (shaft)	External gear pump
80-2	3/4in	KB2	–	–	18 (S)	10 (S)	–
100-2	7/8in	KB3	–	–	28 (S)	–	–
	1in	KB4	–	–	45 (S)	–	–
125-2	1 1/4in	KB5	–	–	71, 88 (S)	–	–
	1 1/2 in	KB6	–	–	100 (S)	–	–
125-4	W32x2x14x9g	K31	40 (Z)	–	–	–	–
140-4	W40x2x18x9g	K33	71 (Z)	–	–	–	–
160-4	W50x2x24x9g	K34	125 (Z) 180 (Z)	–	–	–	–
	1 1/4in	KB8	–	–	71, 88 (S)	–	–
180-4	1 3/4in	KB7	–	–	140, 180 (S)	–	–
	1 1/2 in	KB9	–	–	100 (S)	–	–
224-4	W60x2x28x9g	K35	250 (Z)	250 (Z)	–	–	–
	W70x3x22x0g	K77	355 (Z)	355 (Z)	–	–	–
315-8	W80x3x25x9g	K43	500 (Z)	500 (Z)	–	–	–
400-8	W90x3x28x9g	K76	750 (Z)	750 (Z)	–	–	–
	W100x3x32x9g	K88	1000 (Z)	–	–	–	–
Flange ISO 3019-1 (SAE J744)	Hub for splined shaft	Code	A4VSO A4VSG NG (shaft)	A4CSG NG (shaft)	A10V(S)O/3x NG (shaft)	A10V(S)O/5x NG (shaft)	External gear pump
82-2 (A)	5/8in	K01	–	–	–	–	Series F ²⁾
	3/4in	K52	–	–	18 (S)	10, 18 (U)	–
101-2 (B)	7/8in	K68	–	–	28 (S)	28 (S)	Series N ²⁾
	1in	K04	–	–	45 (S)	45 (S)	PGH 4
127-2 (C)	1 1/4in	K07	–	–	71, 88 (S)	–	–
	1 1/2 in	K24	–	–	100 (S)	85 (S)	PGH 5
152-4 (D)	1 3/4in	K17	–	–	140, 180 (S)	–	–

1) Additional through drives are available on request

2) Bosch Rexroth recommends special versions of the external gear pumps. Please contact us.

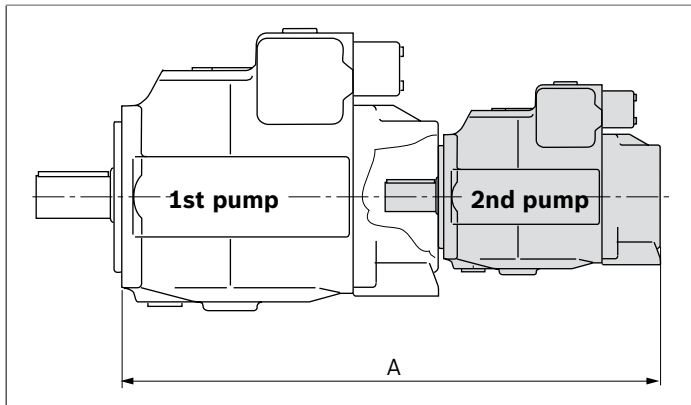
Combination pumps A4VSG + A4VSG**Total length A**

A4VSG (1st pump)	A4VSG (2nd pump)								
	NG40	NG71	NG125	NG180	NG250	NG355	NG500	NG750	NG1000
NG40	570	–	–	–	–	–	–	–	–
NG71	598	622	–	–	–	–	–	–	–
NG125	655	679	743	–	–	–	–	–	–
NG180	679	703	766	778	–	–	–	–	–
NG250	713	737	832	844	912	–	–	–	–
NG355	On request	766	861	873	941	962	–	–	–
NG500	787	811	868	880	984	1005	1100	–	–
NG750	On request	On request	On request	On request	1034	On request	On request	1246	–
NG1000	On request	934	991	1003	1107	On request	1223	1319	1383

Combination pumps A4VSG + A4VSO**Total length A**

A4VSG (1st pump)	A4VSO (2nd pump)								
	NG40	NG71	NG125	NG180	NG250	NG355	NG500	NG750	NG1000
NG40	554	–	–	–	–	–	–	–	–
NG71	582	611	–	–	–	–	–	–	–
NG125	639	668	735	–	–	–	–	–	–
NG180	663	692	758	778	–	–	–	–	–
NG250	697	726	824	844	904	–	–	–	–
NG355	On request	755	853	873	933	962	–	–	–
NG500	771	800	860	880	976	1005	1110	–	–
NG750	On request	On request	On request	On request	1026	On request	On request	1215	–
NG1000	On request	923	983	1003	1099	On request	1233	1288	1361

By using combination pumps, it is possible to have independent circuits without the need for splitter gearboxes. When ordering combination pumps, the type designations of the 1st and 2nd pumps must be connected with a “+” and are combined in one part number. When ordering, the single pumps should be ordered according to type code.

Notice

- ▶ The combination pump type code is shown in shortened form in the order of confirmation.

Example:

A4VSG 125 EO1/30R+A4VSG 71 HM1/10R

- ▶ Each through drive is plugged with a **non-pressure resistant** cover. Before commissioning the units, they must therefore be equipped with pressure-resistant covers. Through drives can also be ordered with a pressure-resistant cover. Please specify in plain text.

Order example:

A4VSG 125 EO1/30R-PPB10K339F

A4VSG 71 HM1/10R-PZB10N00N

It is permissible to use a combination of two single pumps of the same size (tandem pump), considering a dynamic mass acceleration of maximum 10 g (= 98.1 m/s²) without additional support brackets.

For combination pumps consisting of more than two pumps, the mounting flange must be rated for the permissible mass torque.

Notices

- ▶ When adjusting combination pumps, there may be dimensional collisions with another attachment pump. Please check this using the respective data sheets of the individual pumps and controls, or please contact us.

Details on the piping of the combination pumps can be found on page 50.

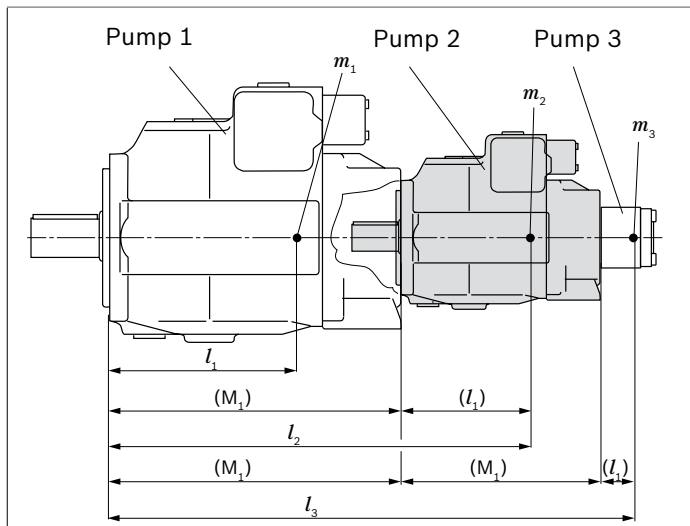

m_1, m_2, m_3	Weight of pump	[kg]
l_1, l_2, l_3	Distance from center of gravity	[mm]

$$T_m = (m_1 \cdot l_1 + m_2 \cdot l_2 + m_3 \cdot l_3) \cdot \frac{1}{102} \text{ [Nm]}$$

Calculation for multiple pumps

- l_1 = Distance, center of gravity, front pump (value from "Permissible mass moment of inertia" table)
- l_2 = Dimension "M1" from through drive drawings (page 34 to 46) + l_1 of the 2nd pump
- l_3 = Dimension "M1" from through drive drawings (page 34 to 46) of the 1st pump + "M1" of the 2nd pump + l_1 of the 3rd pump

Permissible mass moment of inertia

Size			40	71	125	180	250	355	500	750	1000
static	T_m	Nm	1800	2000	4200	4200	9300	9300	15600	19500	19500
			dynamic at 10 g (98.1 m/s ²)	180	200	420	420	930	930	1560	1950
Weight	m	kg	47	60	100	114	214	237	350	500	630
Distance from center of gravity	l_1	mm	120	140	170	180	210	220	230	260	290

Attachment of boost and control circuit pumps

Order code: H02, H04 and H06

As standard, we offer the following external gear pumps as boost and control circuit pumps for attachment:

Code	Piped up attachment pump for	NG	40	71	125	180	250	355	500	750	1000
H02	the boost circuit										
	Design / type		F		N		-	-	-		PGH5
	Size		11	16	25	32	-	-		-	200
H04	shared boost and control circuit (only EO1 and EO1K)										
	Design / type		F		N		-	-	-	-	-
	Size		-	16	25	-	-	-	-	-	-
H06	shared boost and control circuit including pressure relief valve: DB 10 K2-4x/50YV to 50 bar (only HD1T and HD1U)										
	Boost circuit										
	Design / type		F		N		-	-	-	-	PGH5
	Size		11	16	25	32	-	-	-	-	200
	Control circuit										
	Design / type		F				-	-	-	-	PGF2
	Size		08				-	-	-	-	11

Notice

- ▶ The shaft and flange of the external gear pumps AZP with the design F, N and G are adjusted for attachment on axial piston units and therefore special versions. More information on the dimensions and connection options as well as the operating conditions can be found in the data sheets:
AZPF: 10089
AZPN: 10091
AZPG: 10093
PGF2: 10213
PGH4 and PGH5: 10223
- ▶ The leakage of the external gear pumps at different rotational speeds must be noted.

H024 – A4VSG with an attachment pump for the boost circuit, valve block with filter

- ▶ Schematic H02
- Example: H024N with EPG
- NG 40 to 180

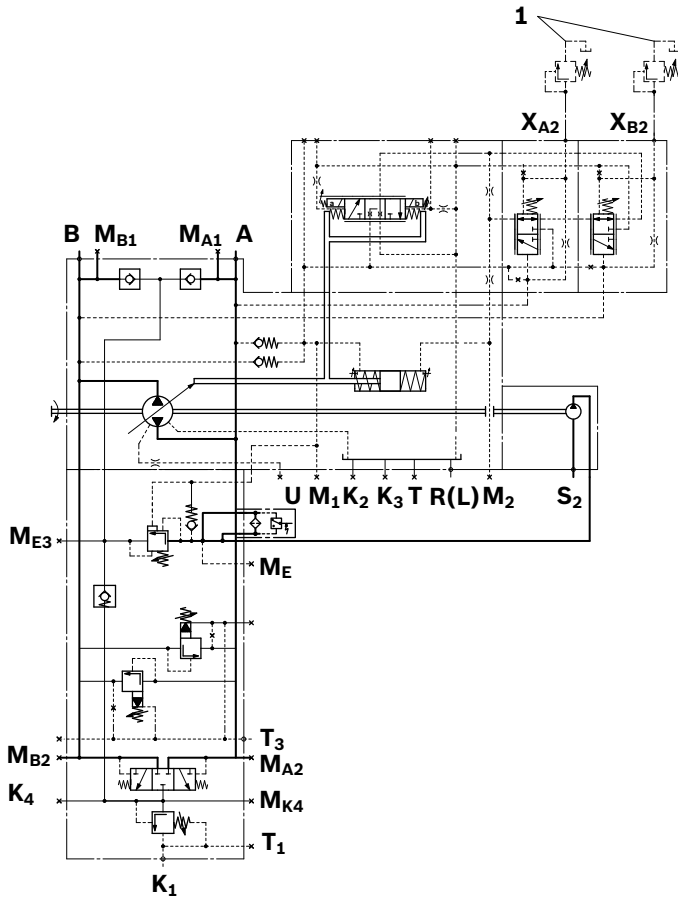

Ports for	State ¹⁾
A, B	Working line (pressure port) O
S	Suction line attachment pump piped up
R(L)	Fill and air bleeding (drain port) O
K₁	Fill and air bleeding (drain port) X
K₂, K₃	Fill and air bleeding (drain port) X
K₄	Accumulator port X
T	Fluid drain X
T₁	Air bleed port pressure relief valve O
T₃	Air bleed port pressure relief valve X
E₁	Filter, supply X
E₂	Filter, return X
X_{A2}, X_{B2}	Pilot pressure port for pressure controller O
ME₃	Measuring boost pressure X
ME	Measuring boost pressure supply X
M_{K4}	Measuring boost pressure X
MA₁, MB₁	Measuring working pressure X
MA₂, MB₂	Measuring working pressure X
M₁, M₂	Measuring control pressure X
U	Bearing flushing X

1 Not included in the scope of delivery

1) O = Must be connected (plugged when delivered)
X = Plugged (in normal operation)

Example: A4VSG 180....H024N

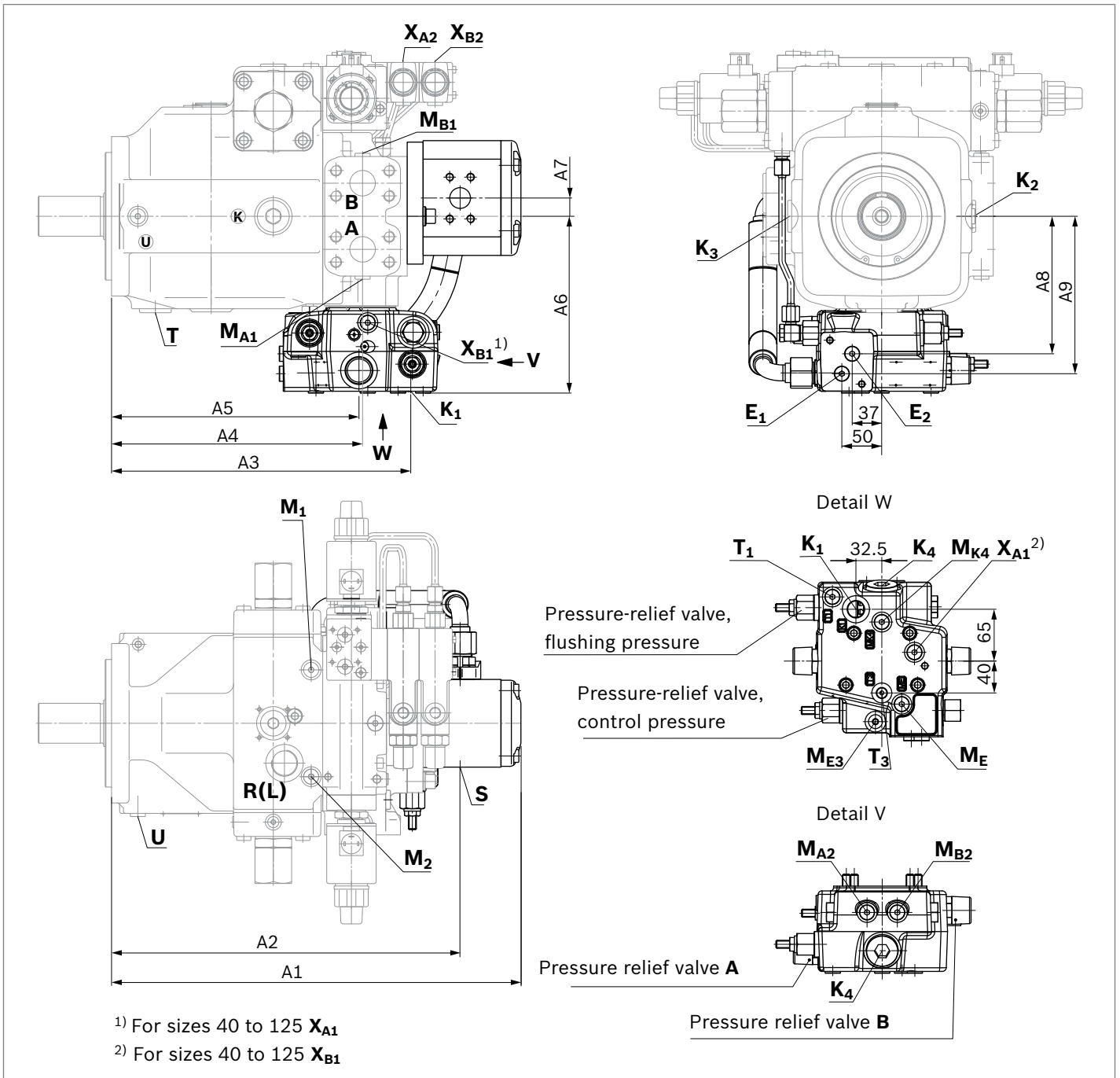

NG	A1	A2	A3	A4	A5	A6	A7	A8	A9
40	357	310	297	227	On request	194.3	18.8	150	175
71	395	338	322	258.5	257	196.8	18.7	On request	On request
125	463	402	376	315	311	217	22.9	172.5	197.5
180	495	430	375.5	315	310.5	221.8	22.9	172.5	197.5

Installation instructions

General

The axial piston unit must be filled with hydraulic fluid and air bled during commissioning and operation. This must also be observed following a longer standstill as the axial piston unit may empty via the hydraulic lines.

Particularly in the installation position "drive shaft upwards", filling and air bleeding must be carried out completely as there is, for example, a danger of dry running.

The case drain fluid in the housing area must be directed to the reservoir via the highest available drain port (**T**, **R(L)**, **K₂**, **K₃**).

For combination pumps, the leakage must be drained off at each pump.

If a shared drain line is used for several units, make sure that the respective case pressure is not exceeded. The shared drain line must be dimensioned to ensure that the maximum permissible case pressure of all connected units is not exceeded in any operating conditions, particularly on cold start. If this is not possible, separate drain lines must be laid, if necessary.

To achieve favorable noise values, decouple all connecting lines using elastic elements and avoid above-reservoir installation.

In all operating conditions, the suction line and drain line must flow into the reservoir below the minimum fluid level.

The permissible suction height h_s results from the total pressure loss. However, it must not be higher than $h_{s \max} = 800$ mm. The minimum suction pressure at port **S** must also not fall below 0.8 bar absolute during operation and during cold start.

Notice

In certain installation positions, an influence on the control or closed loop control can be expected. Gravity, dead weight and case pressure can cause minor characteristic shifts and changes in response time.

Installation position

See the following examples **1** to **12** on the next pages. Further installation positions are available upon request. Recommended installation position: **1** and **2**

Installation instructions

Below-reservoir installation (standard)

Below-reservoir installation means that the axial piston unit is installed outside of the reservoir and below the minimum fluid level of the reservoir.

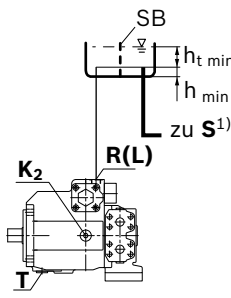
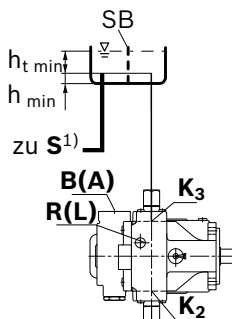
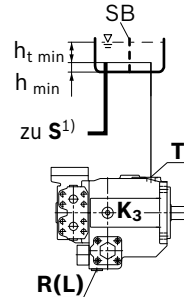
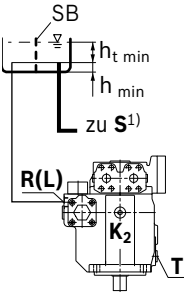
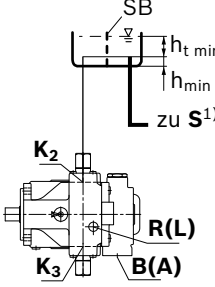
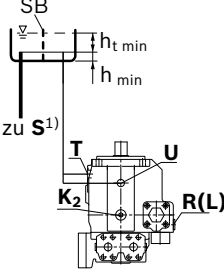
Installation position	Air bleed	Filling	Installation position	Air bleed	Filling
<p>1</p> 	R(L)	R(L)	<p>4</p> 	K₃	K₃
<p>2</p> 	T	T	<p>5</p> 	R(L)	R(L)
<p>3</p> 	K₂	K₂	<p>6</p> 	T	T

Bearing flushing at **U** port required.
 For details, see page 6

Key	
R(L)	Filling/air bleeding
S	Suction port
T, K₂, K₃	Drain port
SB	Baffle (baffle plate)
$h_{t\ min}$	Minimum required immersion depth (200 mm)
$h_{\ min}$	Minimum required distance to reservoir bottom (100 mm)
$h_{ES\ min}$	Minimum necessary height required to protect the axial piston unit from draining (25 mm)
$h_{S\ max}$	Maximum permissible suction height (800 mm)

1) Information on the attachment pump can be found in the respective data sheets (see page 47)

Above-reservoir installation

Above-reservoir installation means that the axial piston unit is installed above the minimum fluid level of the reservoir. To prevent the axial piston unit from draining, a height difference $h_{ES\ min}$ of at least 25 mm at port R(L), **T** is required in position 12. Observe the maximum permissible suction height $h_{S\ max} = 800\ mm$.

Installation position	Air bleed	Filling
7	R(L)	R(L) (F)

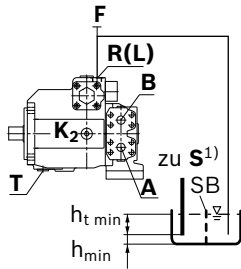

8	T	T (F)
---	---	-------

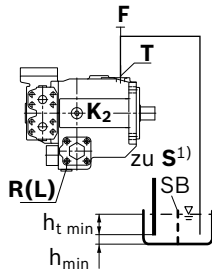

9	K ₂	K ₂ (F)
---	----------------	--------------------

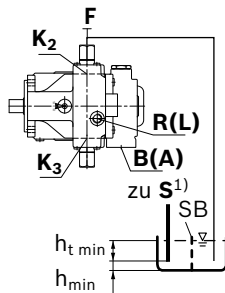

1) Information on the attachment pump can be found in the respective data sheets (see page 47)

Notice

Port **F** is part of the external piping and must be provided on the customer side to make filling and air bleeding easier.

Installation position	Air bleed	Filling
10	K ₃	K ₃ (F)

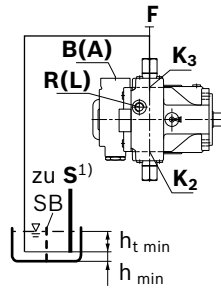

11	R(L)	R(L) (F)
----	------	----------

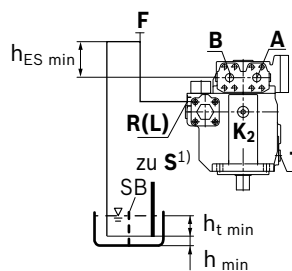

12	T	T (F)
----	---	-------

Bearing flushing at **U** port required.
For details, see page 6

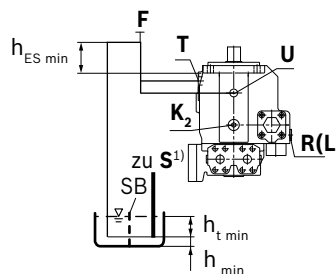

Project planning notes

- ▶ The A4VSG axial piston variable pump is designed to be used in closed circuit.
- ▶ The project planning, installation and commissioning of the axial piston unit requires the involvement of qualified skilled personnel.
- ▶ Before using the axial piston unit, please read the corresponding instruction manual completely and thoroughly. If necessary, this can be requested from Bosch Rexroth.
- ▶ Before finalizing your design, please request a binding installation drawing.
- ▶ The specified data and notes contained herein must be observed.
More information on the products can be found in the data sheets on page 1.
- ▶ Depending on the operating conditions of the axial piston unit (working pressure, fluid temperature), the characteristic curve may shift.
- ▶ The characteristic curve may also shift due to the dither frequency or control electronics.
- ▶ Preservation: Our axial piston units are supplied as standard with preservative protection for a maximum of 12 months. If longer preservative protection is required (maximum 24 months), please specify this in plain text when placing your order. The preservation periods apply under optimal storage conditions, details of which can be found in the data sheet 90312 or in the instruction manual.
- ▶ Not all versions of the product are approved for use in a safety function according to ISO 13849. Please consult the responsible contact person at Bosch Rexroth if you require reliability parameters (e.g. $MTTF_d$) for functional safety.
- ▶ Depending on the type of control used, electromagnetic effects can be produced when using solenoids. When a direct current is applied, solenoids do not cause electromagnetic interference nor is their operation impaired by electromagnetic interference.
Other behavior can result when a modulated direct current (e.g. PWM signal) is applied. There is a possible electromagnetic influence when the solenoid is energized with modulated direct current (e.g. PWM signal). Potential electromagnetic interference for persons (e.g. persons with a pacemaker) and other components must be tested by the machine manufacturer.
- ▶ Pressure controllers are not safeguards against pressure overload. Be sure to add a pressure relief valve to the hydraulic system.
- ▶ For drives that are operated for a long period with constant rotational speed, the natural frequency of the hydraulic system can be stimulated by the excitation frequency of the pump (rotational speed frequency $\times 9$). This can be prevented with suitably designed hydraulic lines.
- ▶ Please note the details regarding the tightening torques of port threads and other threaded joints in the instruction manual.
- ▶ Working ports:
 - The ports and fastening threads are designed for the specified maximum pressure. The machine or system manufacturer must ensure that the connecting elements and lines correspond to the specified application conditions (pressure, flow, hydraulic fluid, temperature) with the necessary safety factors.
 - The working ports and function ports are only intended to accommodate hydraulic lines.

Safety instructions

- ▶ During and shortly after operation, there is a risk of burning on the axial piston unit and especially on the solenoids. Take the appropriate safety measures (e.g. by wearing protective clothing).
- ▶ Moving parts in control equipment (e.g. valve spools) can, under certain circumstances, get stuck in position as a result of contamination (e.g. contaminated hydraulic fluid, abrasion, or residual dirt from components). As a result, the hydraulic fluid flow and the build-up of torque in the axial piston unit can no longer respond correctly to the operator's specifications. Even the use of various filter elements (external or internal flow filtration) will not rule out a fault but merely reduce the risk. The machine/system manufacturer must test whether additional measures are required on the machine for the relevant application in order to bring the driven consumer into a safe position (e.g. safe stop) and ensure any measures are properly implemented.
- ▶ In certain conditions, moving parts in high pressure relief valves might get stuck in an undefined position due to contamination (e.g. contaminated hydraulic fluid). This can result in restriction or loss of load holding functions in lifting winches. Therefore it is the machine and/or system manufacturers responsibility to make sure that the load can always be put in a safe mode if needed. Also, he needs to ensure that these measures are properly implemented.